

Advancements in Coated Conductors for Magnet and Power Applications

V. Selvamanickam, G. Majkic, I. Kesgin, Y. Yao,
T. Shi, Y. Liu, X. Cai, X. Tao, N. Khatri,
and E. Galtsyan

University of Houston, Houston, TX, USA

Y. Chen, C. Lei, S. Sambandam, and X. Xiong
SuperPower Inc., Schenectady, NY, USA

Successful scale up of IBAD-MOCVD based 2G HTS wires

- 1,000 m 2G HTS wire first demonstrated in July 2008
1,400 m lengths are now routinely produced.
- High throughput processing (>> 100 m/h* in IBAD & buffer processes, > 100 m/h* in other processes)

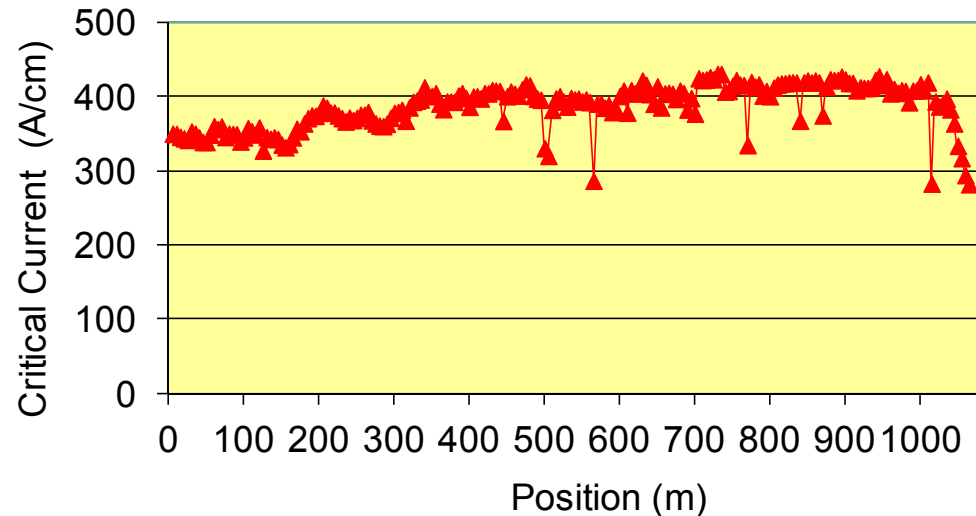

Metric	2006	2011
Total wire shipped (meters)	10,000	150,000 (projected for the year)
Average I_c (A/4 mm)	80	122
I_c range (A/4 mm)	40 – 118	80 - 165

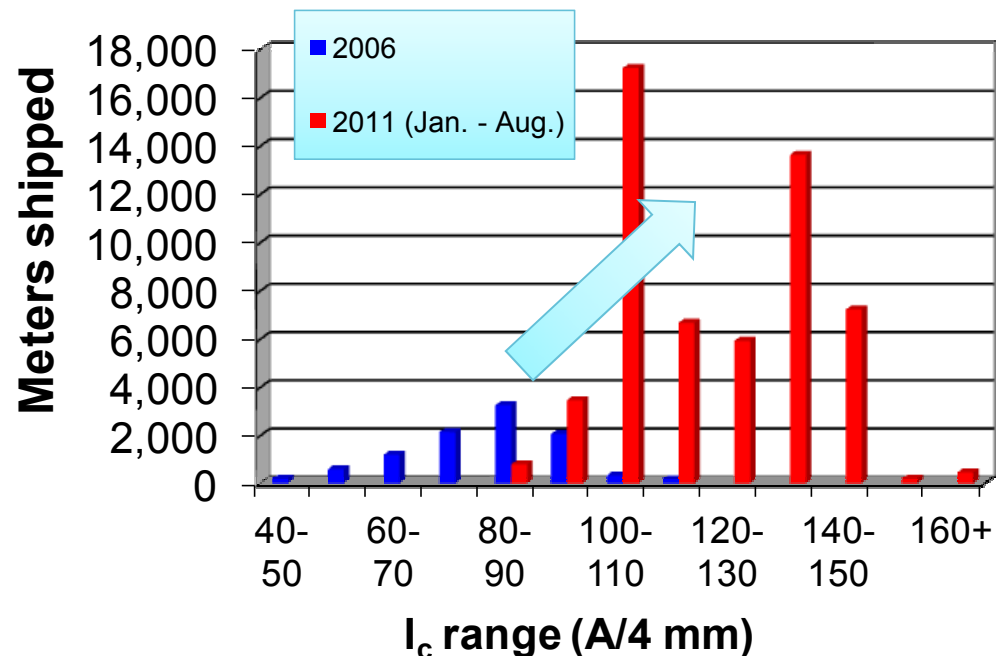

*4 mm wide equivalent

2G HTS wire technology timeline

- 2000 – 2006: Scale up 2G HTS wire technology to manufacturing
- 2006 – 2010: Improvement of in-field performance based on process optimization at 77 K
- 2011 onwards: Focus on in-field performance based on process optimization at operating conditions of interest to coil-based applications
 - 4.2 K, 15+ T: High-field magnets, SMES, High Energy Physics, Fusion Reactors...
 - 20 K – 65 K, 2+T: Wind generators, Automotive motors, SMES, Aerospace...

Opportunity to achieve large increase in critical current performance at device operating condition through combination of independent engineering of nanoscale defects for improved in-field performance and thick film optimization for high currents at 77 K

Improved pinning by Zr doping of MOCVD HTS wires

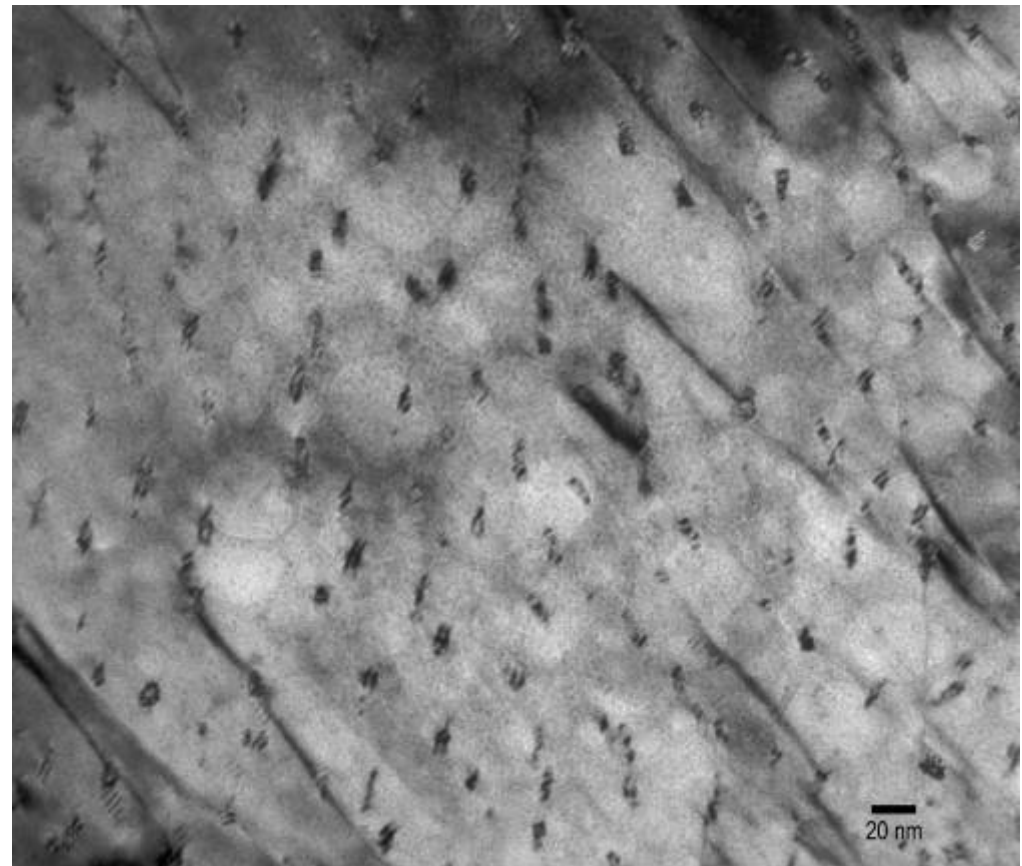
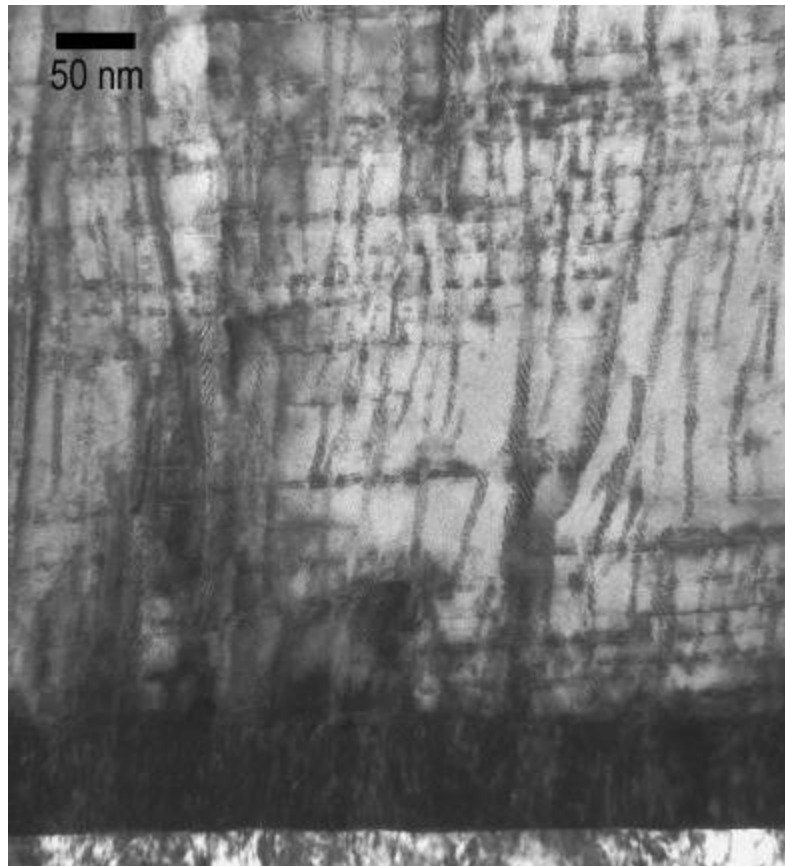

5 nm sized, few hundred nanometer long BZO nanocolumns with ~ 35 nm spacing created during in situ MOCVD process with 7.5% Zr

Improved pinning by Zr doping of MOCVD HTS conductors

- Systematic study of improved pinning by Zr addition in MOCVD films at UH.
- Two-fold improvement in in-field performance achieved !

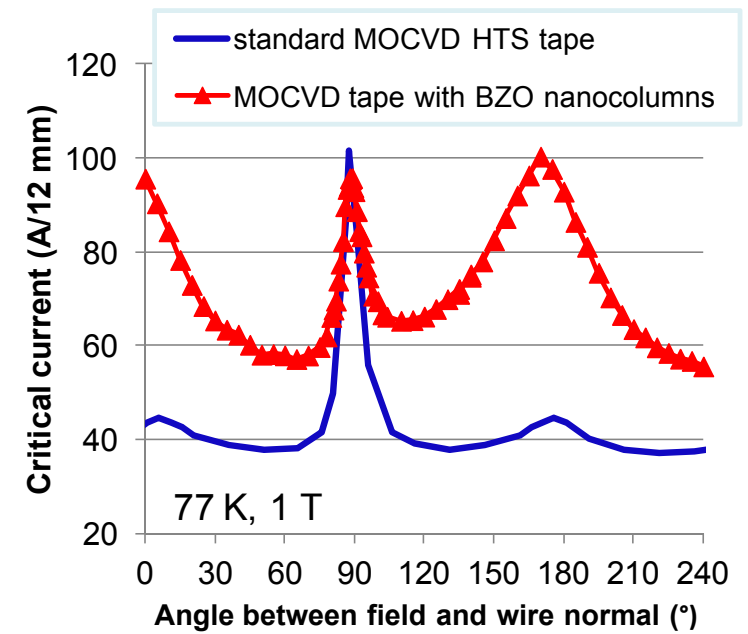
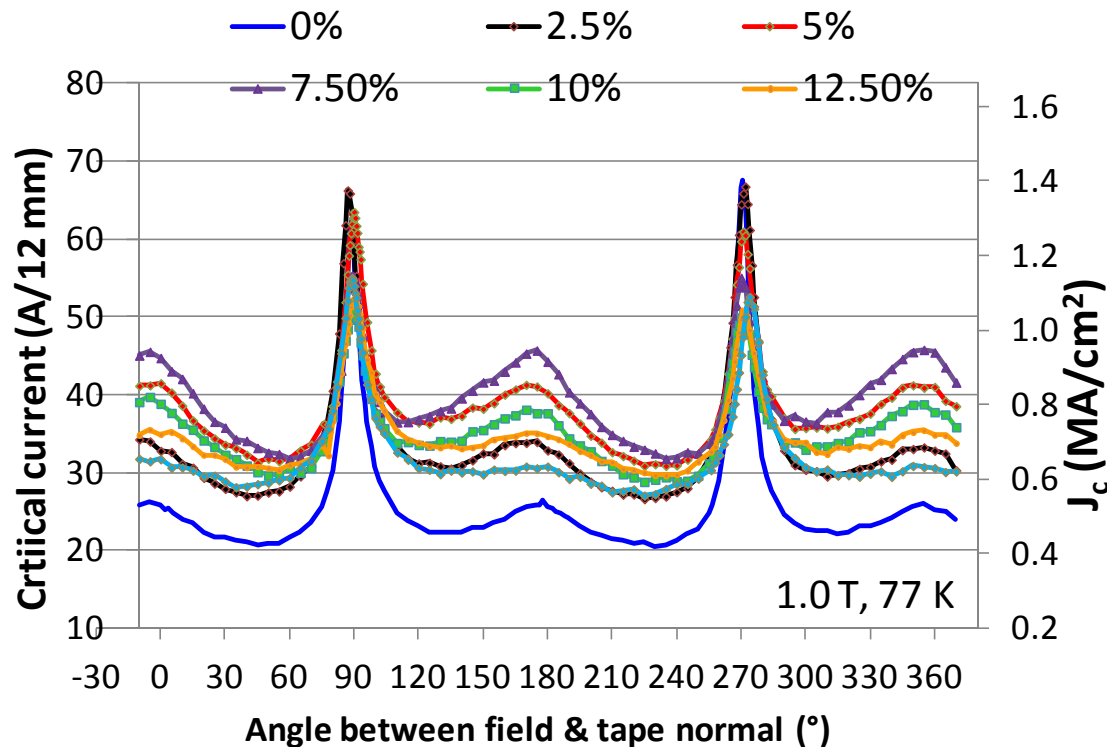

Process for improved in-field performance successfully transferred to manufacturing at SuperPower

Ultra high-field magnets demonstrated at 4.2 K with Zr-doped MOCVD conductors

- $J_e \sim 300 \text{ A/mm}^2$
- Stress levels 300 – 400 MPa

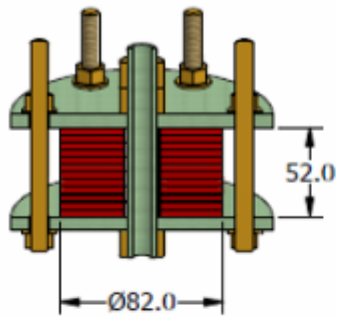

SuperPower I.
 $B_{max} = 26.8 \text{ T}$
 $\Delta B = 7.8 \text{ T}$

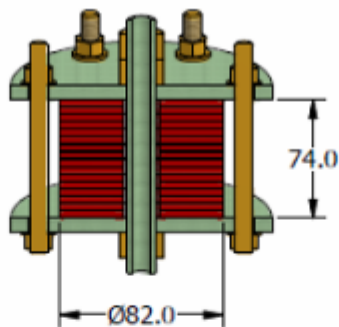

SuperPower II.
 $B_{max} = 27 \text{ T}$
 $\Delta B = 7 \text{ T}$

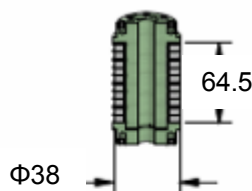

NHMFL II.
 $B_{max} = 35.4 \text{ T}$
 $\Delta B = 4.2 \text{ T}$

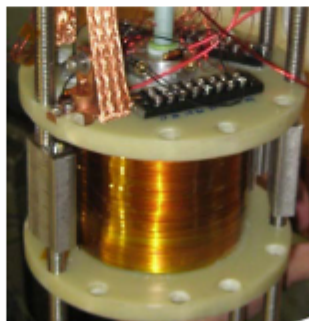
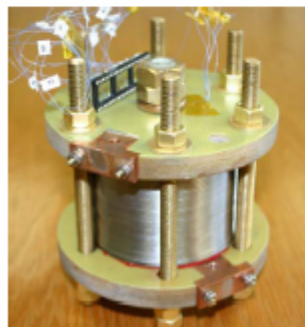
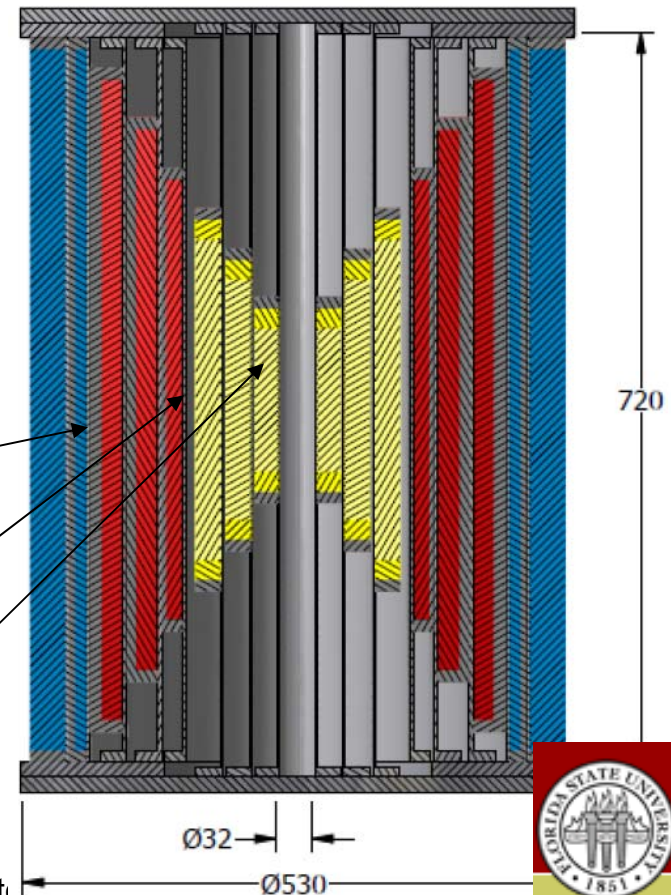

NbTi
 Nb₃Sn
 REBCO

32 T, large bore all superconducting magnet being constructed with coated conductors at NHFML

Large improvements in in-field I_c of Zr-doped conductors at intermediate temperatures too

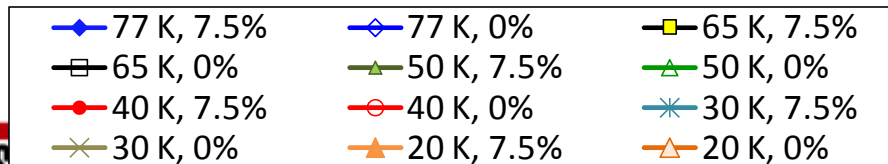
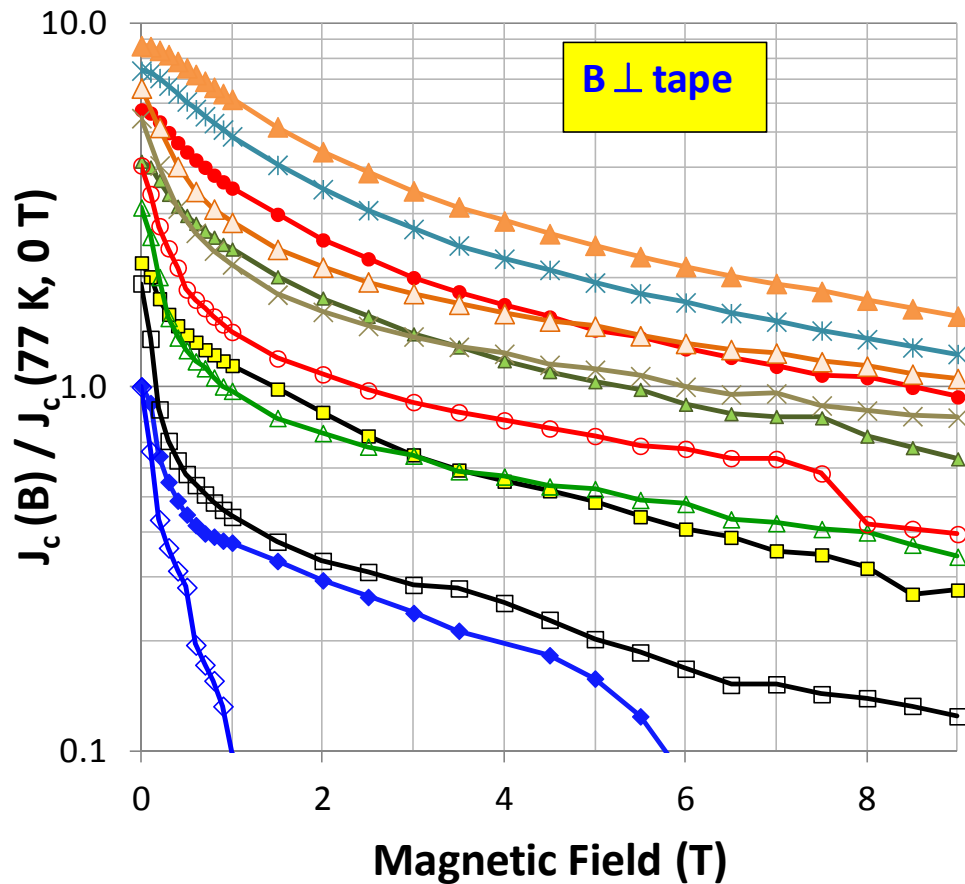

Field & Temperature	Lift Factor of 77 K, zero field I_c		Lift factor of Zr-doped wire is higher by
	Undoped	Zr-doped	
65 K, 3 T	0.29	0.65	2.24
50 K, 3 T	0.65	1.4	2.15
40 K, 3 T	0.91	2.0	2.2
30 K, 3 T	1.38	2.72	1.97
20 K, 3 T	1.80	3.45	1.92

*At 3 T, over a wide range of temperatures, quantity of wire required for device is **reduced by 1/2** greatly improving economics of the device.*

Substantial changes in lower temperature performance characteristics with Zr doping

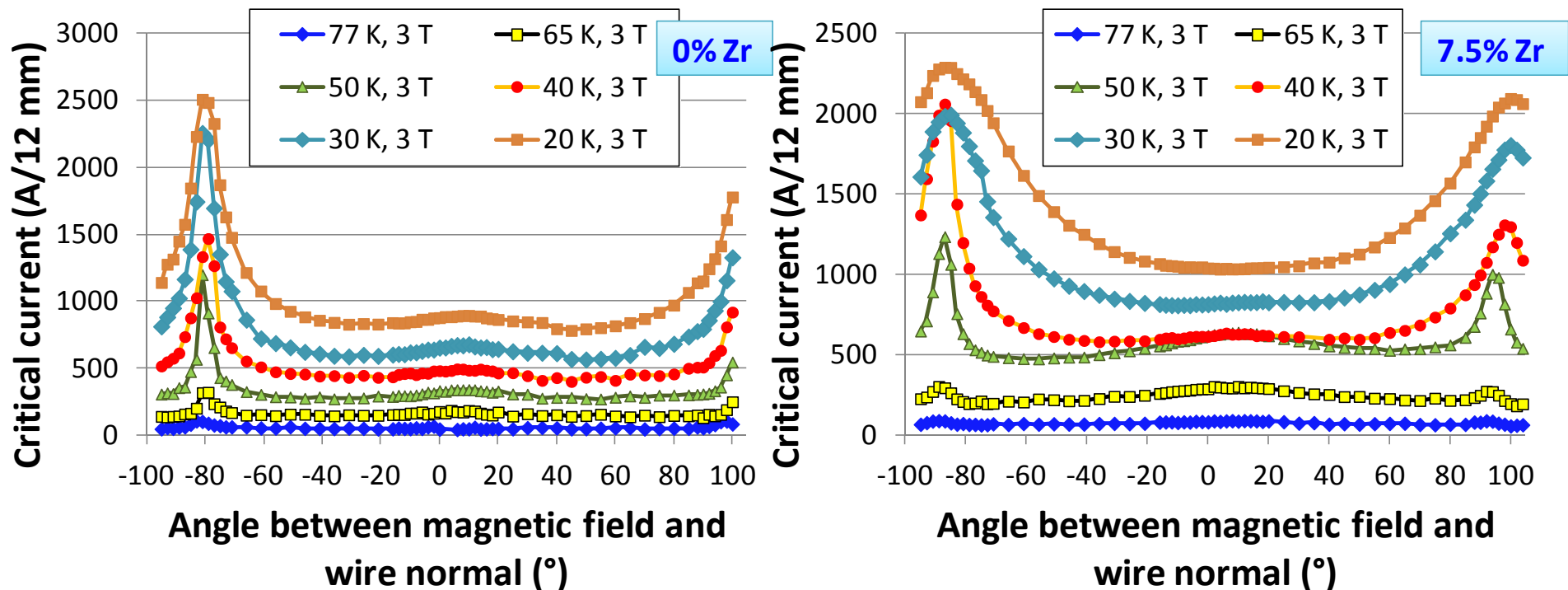

Pronounced broadening of peak at $B \parallel a-b$ in Zr-doped tapes at temperatures below 40 K

Significant broadening of a-b plane peak in Zr-doped conductors at lower temperatures

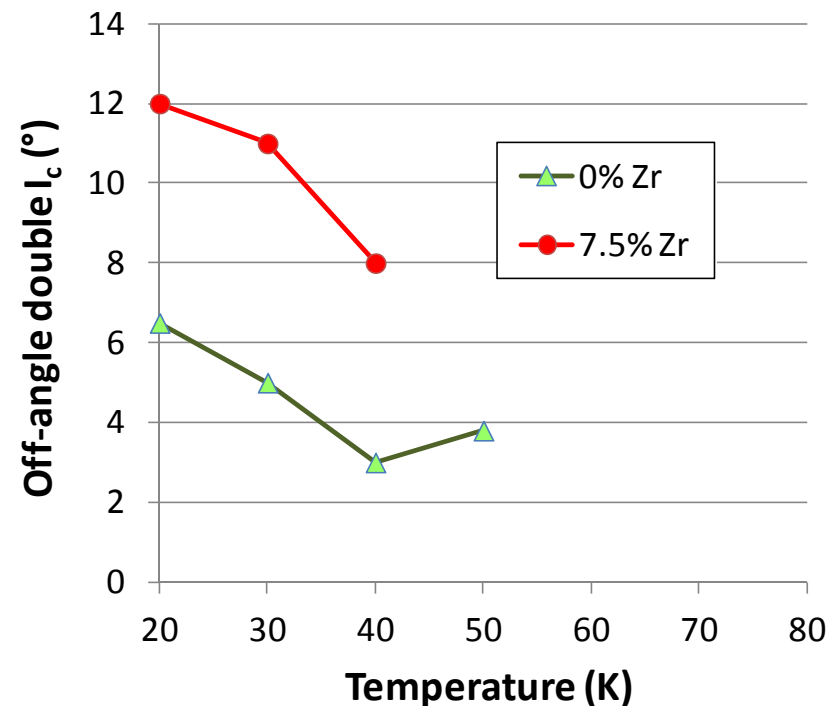
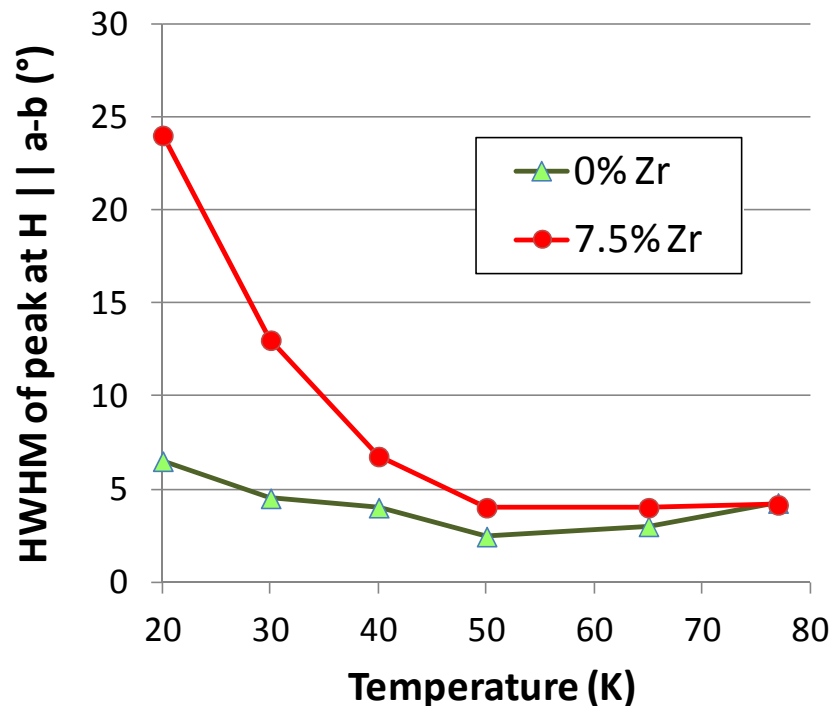

For Off-angle Double I_c (OADI) details see V. Braccini et al. *Supercond. Sci. Technol.* **24**, 035001 (2011)

Broadening of a-b plane peak at temperatures below 40 K is an added benefit of Zr-doped conductors for coil-based applications

Thick film multilayers of Zr doped $(Y,Gd)_{1.5}$ and $(Y,Gd)_{1.2}$ compositions

- 7.5% Zr doping. 0.75 μm HTS film deposited in each pass.
- Zero-field and in-field performance measured after each pass.

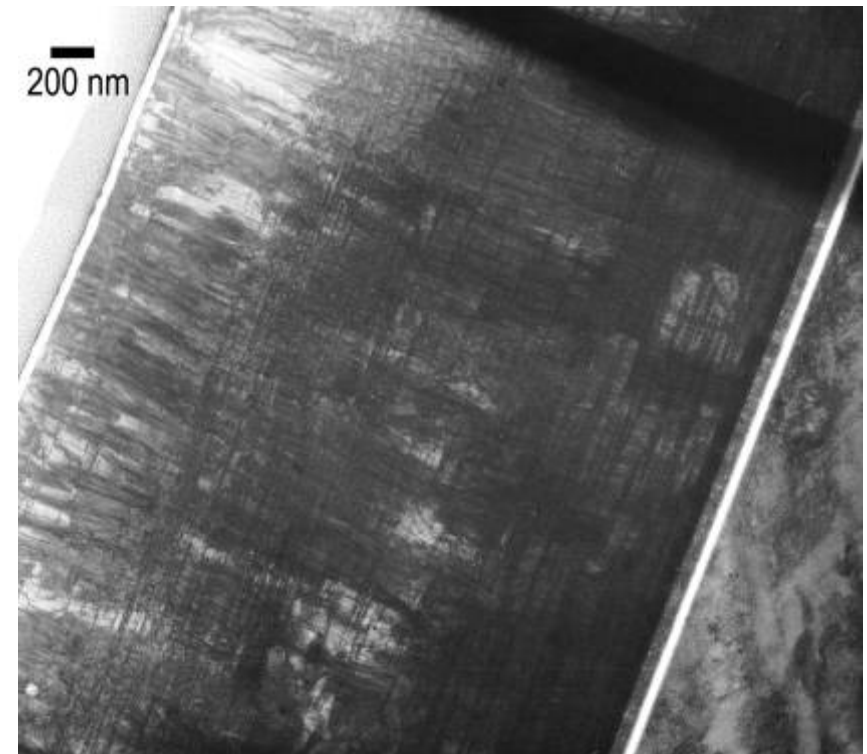
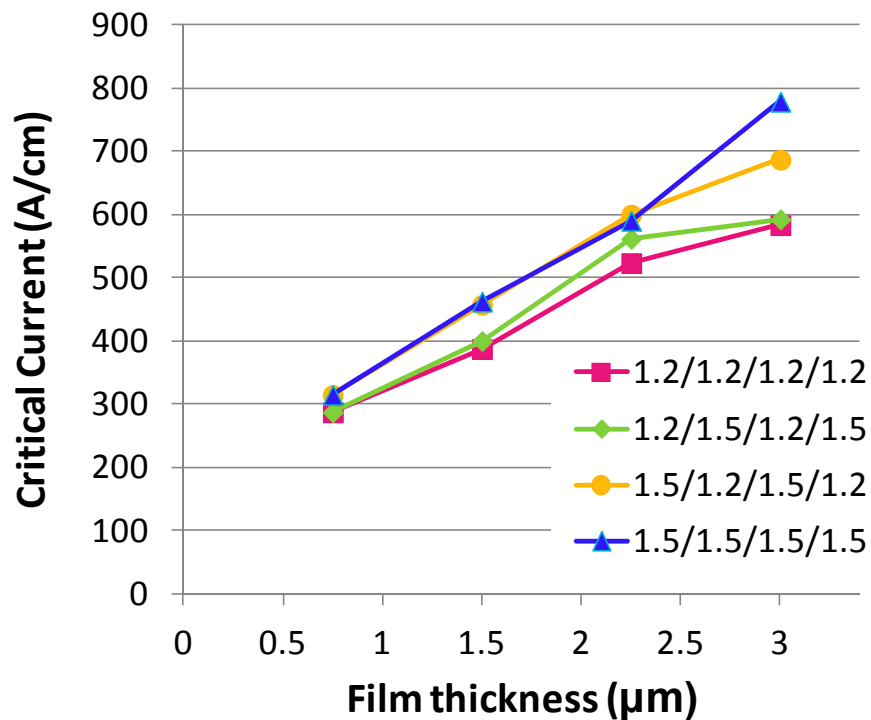

In-field performance of thick film multilayers of Zr doped $(Y,Gd)_{1.5}$ and $(Y,Gd)_{1.2}$ compositions

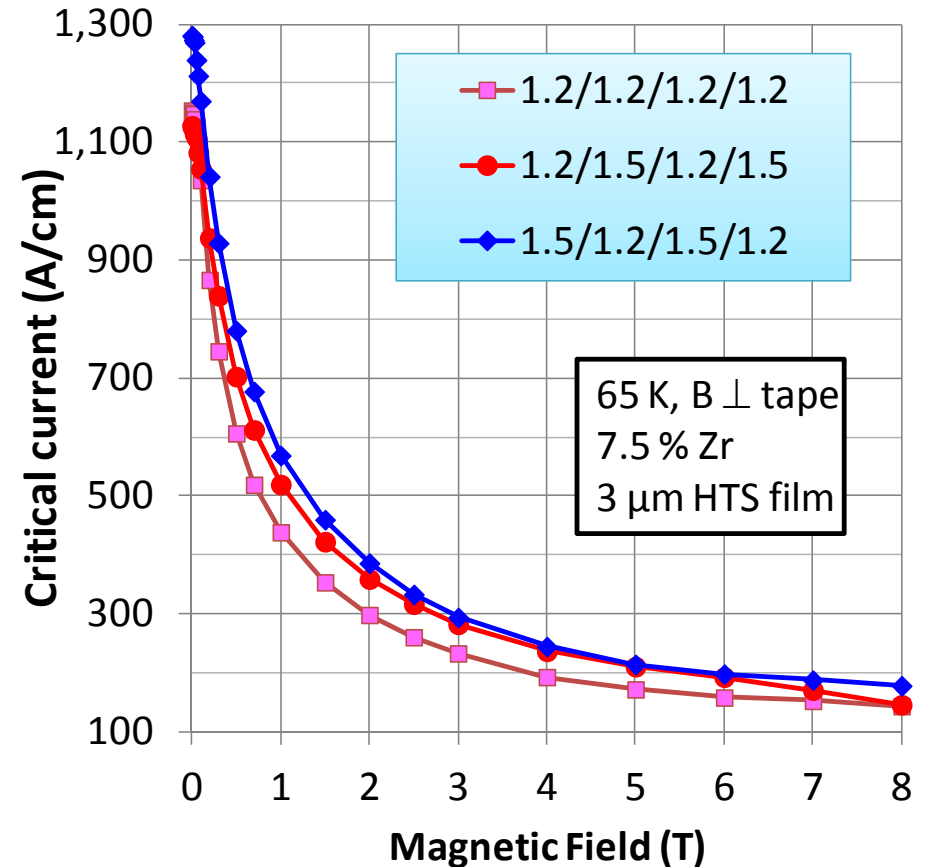
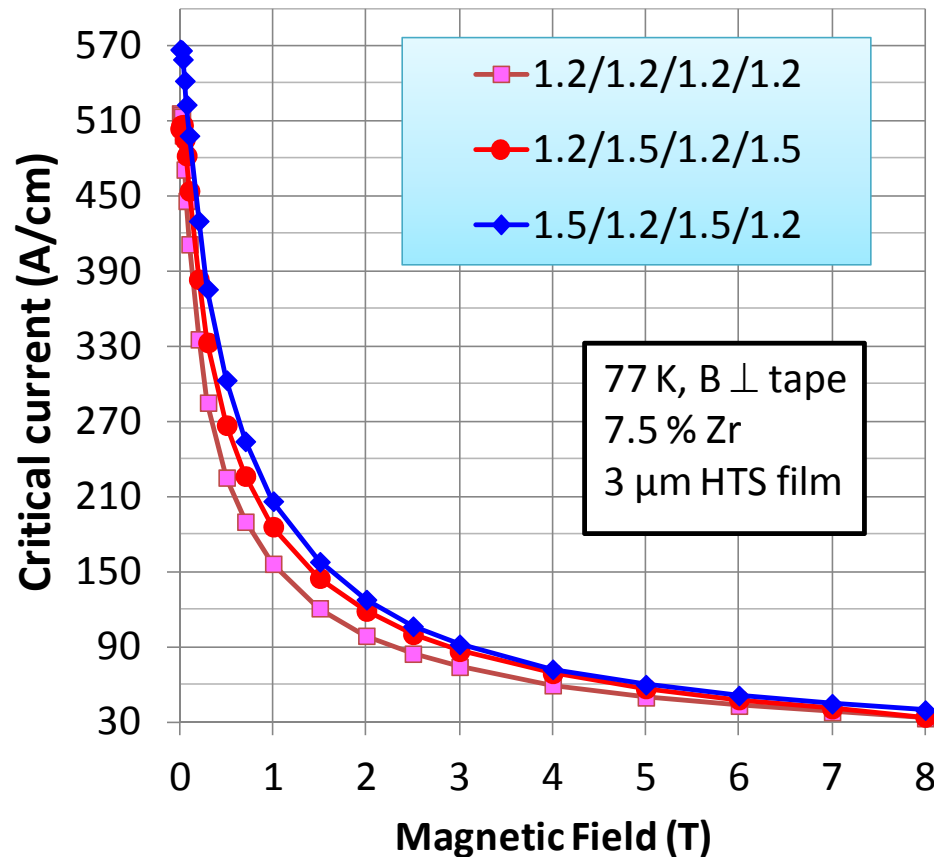

Measurements by Y. Zuev & A. Goyal ORNL

Performance of 2G HTS wire at 3 T at high temperatures

(YGd) content in each of 4 layers	I_c (A/cm)	
	(77 K, 3 T)	(65 K, 3 T)
1.2/1.2/1.2/1.2	74.3	233
1.2/1.5/1.2/1.5	86.8	283
1.5/1.2/1.5/1.2	92.3	294

- Even at this I_c value at 77, 3 T, price of wire is ~ \$ 1000/kA-m!
- 77 K is NOT the relevant temperature for applications involving fields of a few Tesla
- ***I_c at 77 K, 3 T is not a good benchmark for 2G HTS wire performance***

Multiple strategies to enhance in-field performance at relevant temperatures

- Superconductor process modification
 - Chemical modifications in MOCVD to modify defect density, orientation and size
 - Influence of Zr content at fixed rare-earth type and content
 - Influence of rare earth type and content at fixed Zr content
 - Influence of other dopants
 - Influence of deposition rate
 - Buffer surface modification buffer prior to superconductor growth
 - Post superconductor processing modification such as post annealing

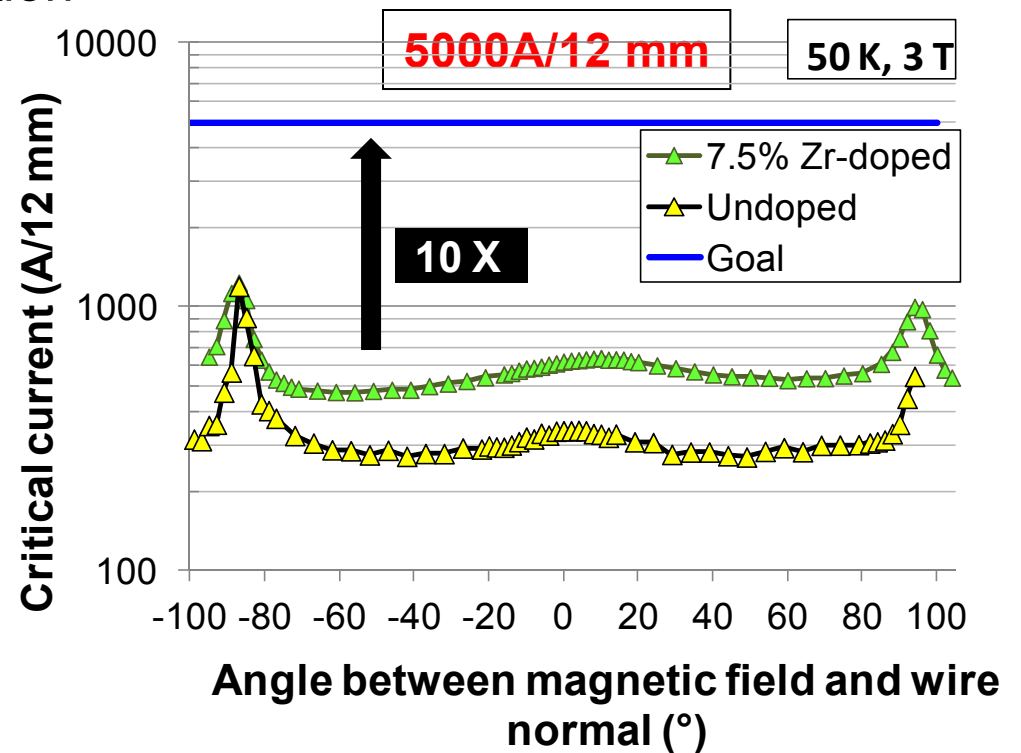

Opportunities to multiply nanodefekt density and hence pinning with higher dopant levels

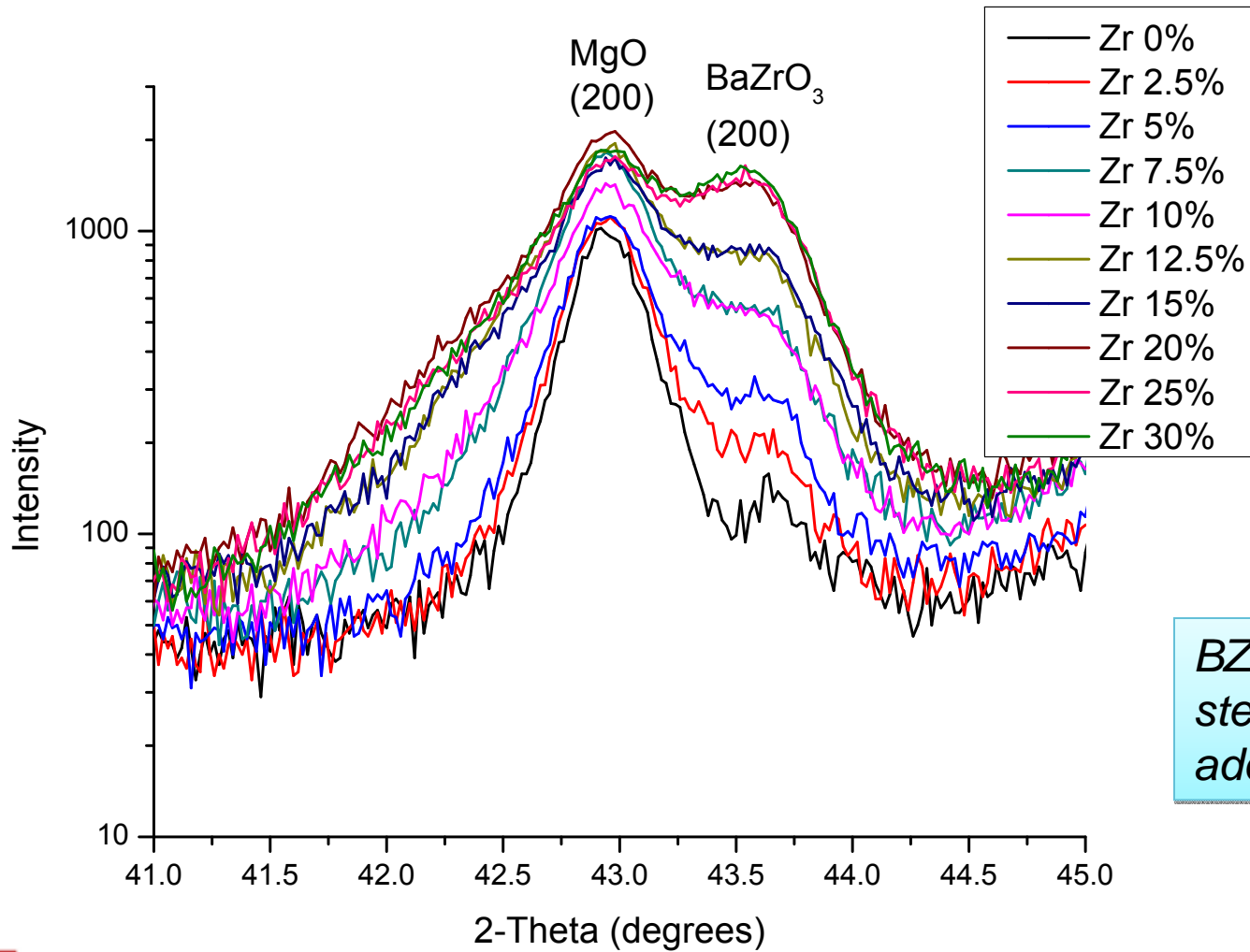

BZO content increases steadily with Zr addition

Density of BZO nanorods in high Zr content films

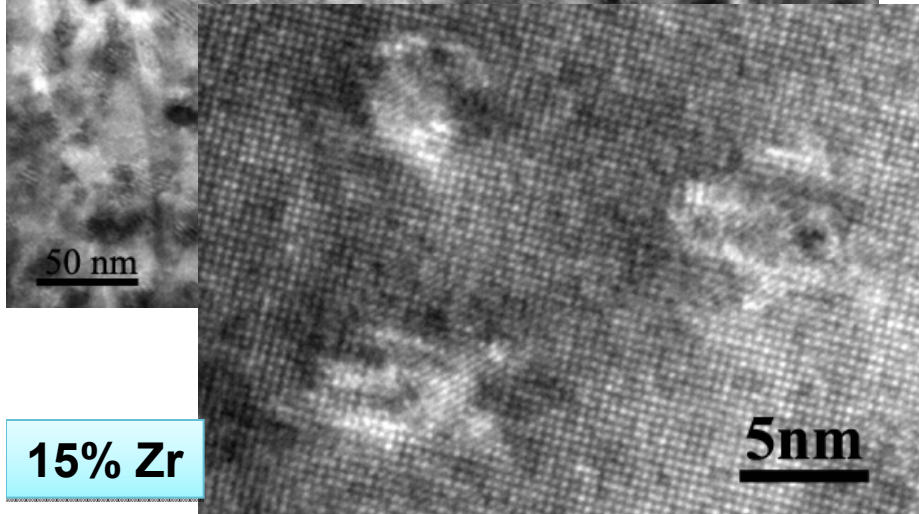
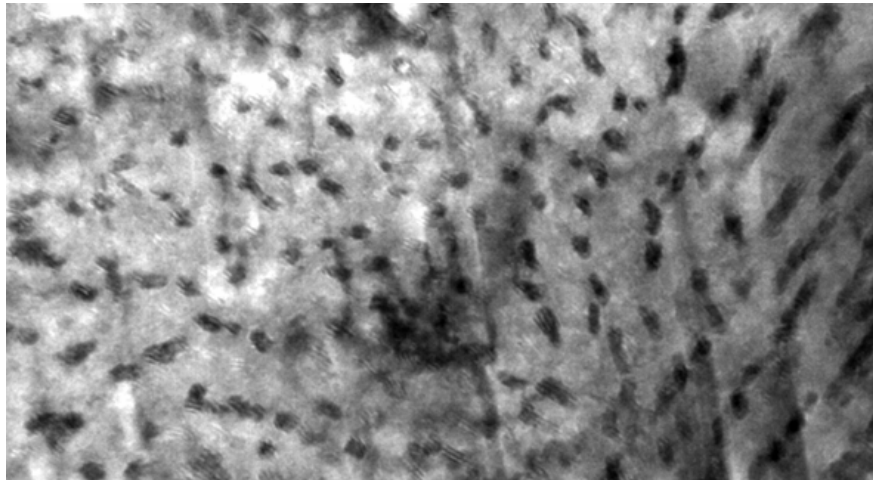

15% Zr

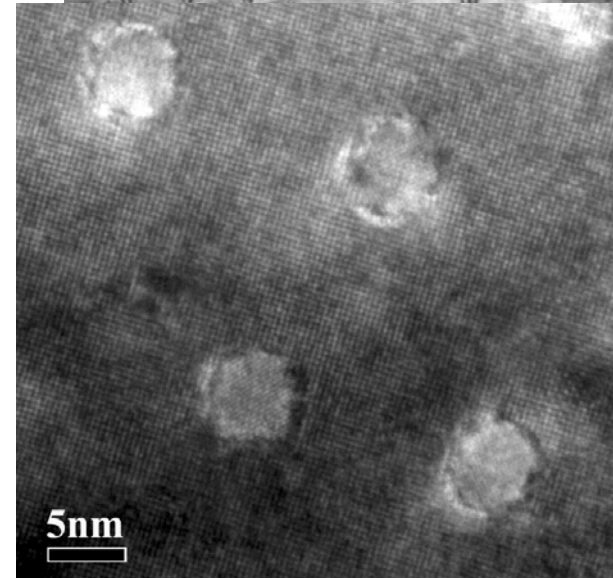
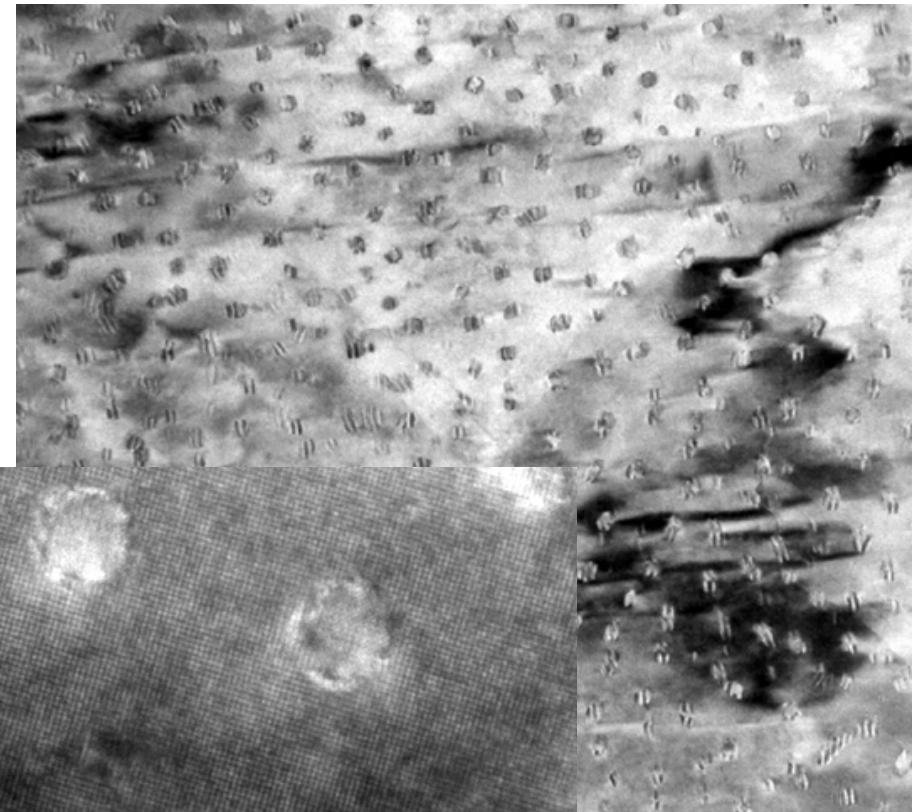

20% Zr

20 nm
HV=200.0kV
Direct Mag: 120000x

From 107 nanorods, BZO spacing = 17 nm
& areal density = $3.7 \times 10^{11} \text{ cm}^{-2}$

From 160 nanorods, BZO spacing = 19 nm
& areal density = $2.9 \times 10^{11} \text{ cm}^{-2}$

Size distribution of BZO nanorods in high Zr content films

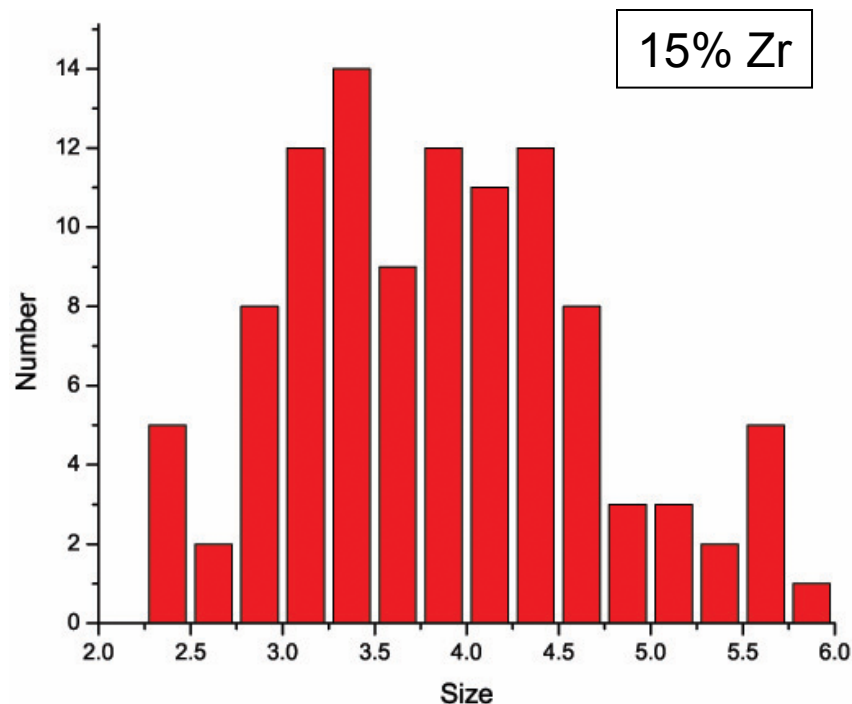

Average size: 3.86 nm
Areal content: 4.45%

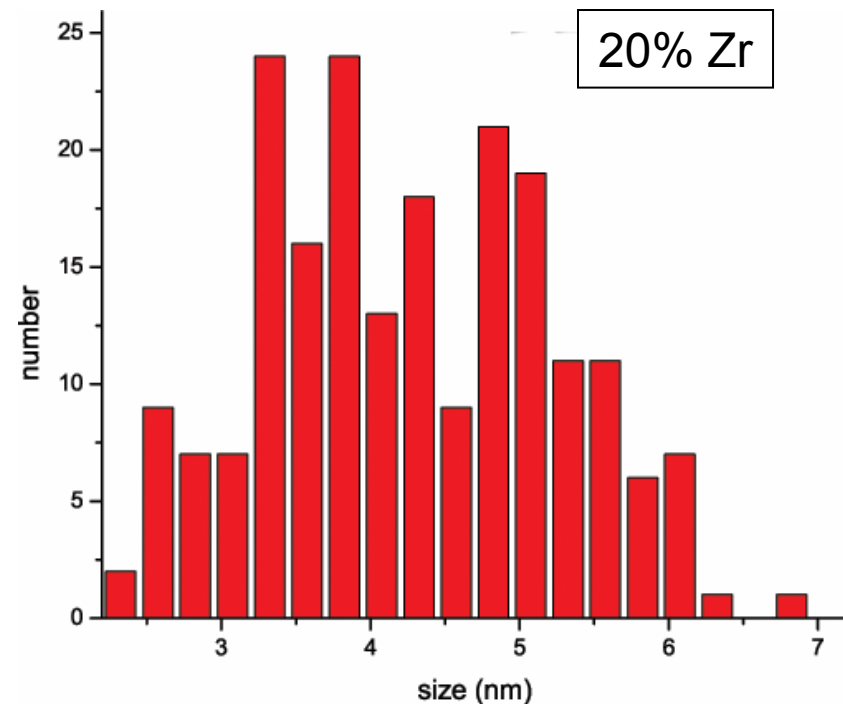

Average size: 4.25 nm
Areal content: 4.45%

Performance at higher Zr doping levels

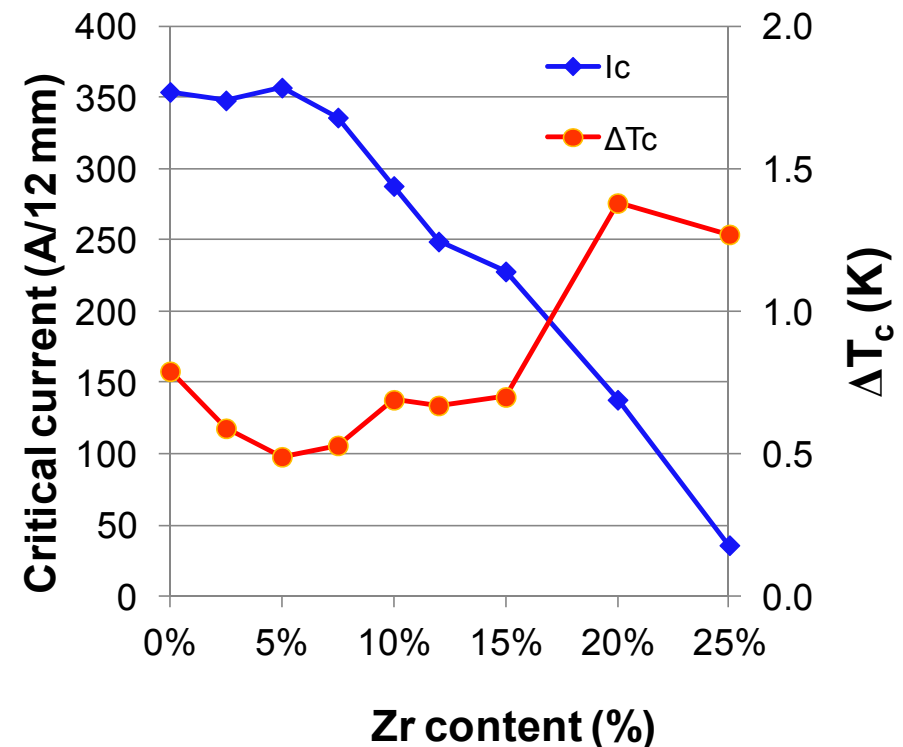
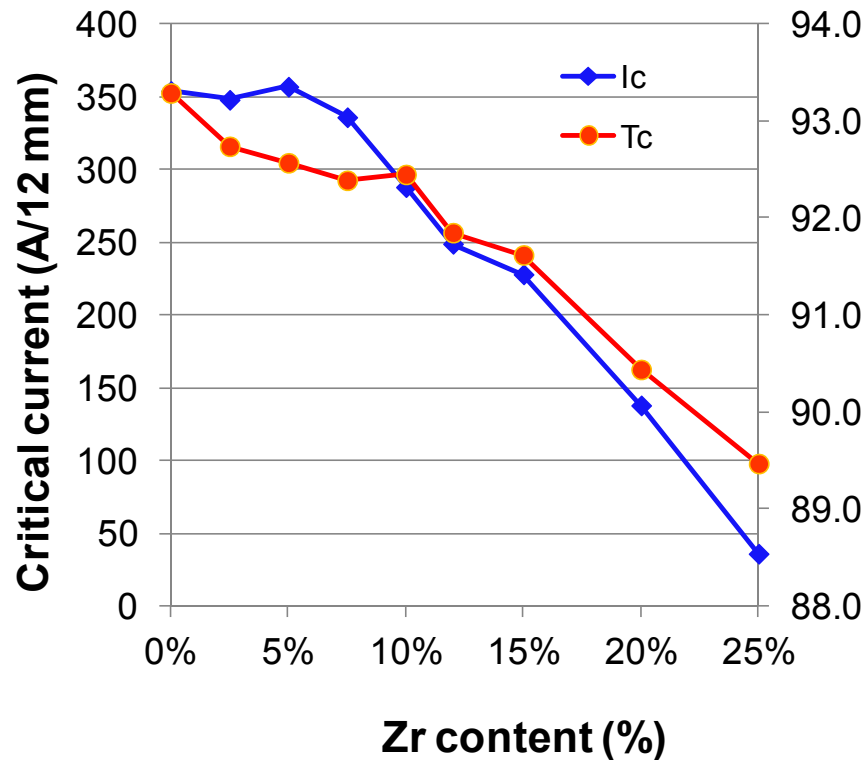

- Zero-field critical current drops beyond 7.5% Zr addition.
- Sharper drop in T_c beyond 10% Zr addition (3 K from 10% to 25%)
- Transition width increases by 0.5 K beyond 15%

Maximizing defect incorporation: Why does I_c reduce with increased Zr addition?

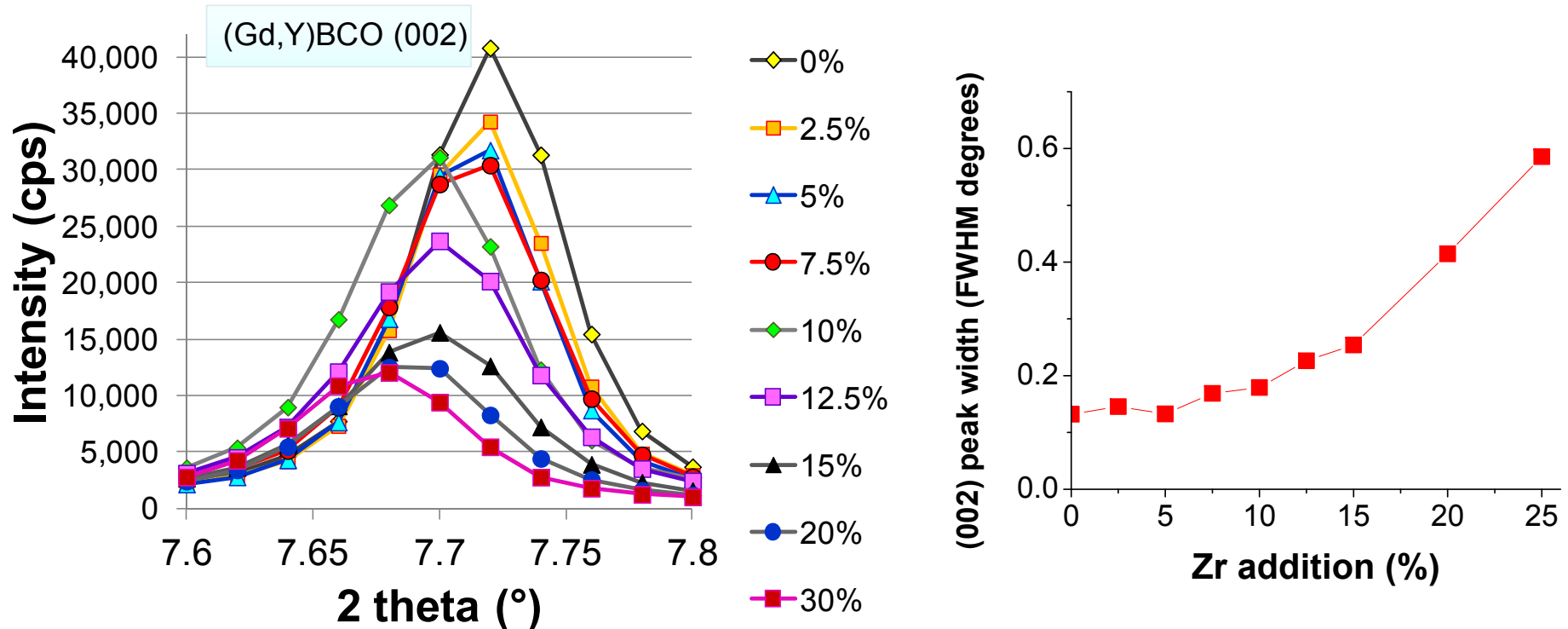

- (Gd,Y)BCO lattice constant increases steadily with increasing Zr
- (Gd,Y)BCO peak intensity decreases steadily with increasing Zr, sharply beyond 10%
- Width of rocking curve of (002) of (Gd,Y)BCO increases beyond 10%

Opportunities to restore high I_c with high Zr content films by improving HTS crystallinity

Number of structural changes with increasing Zr addition

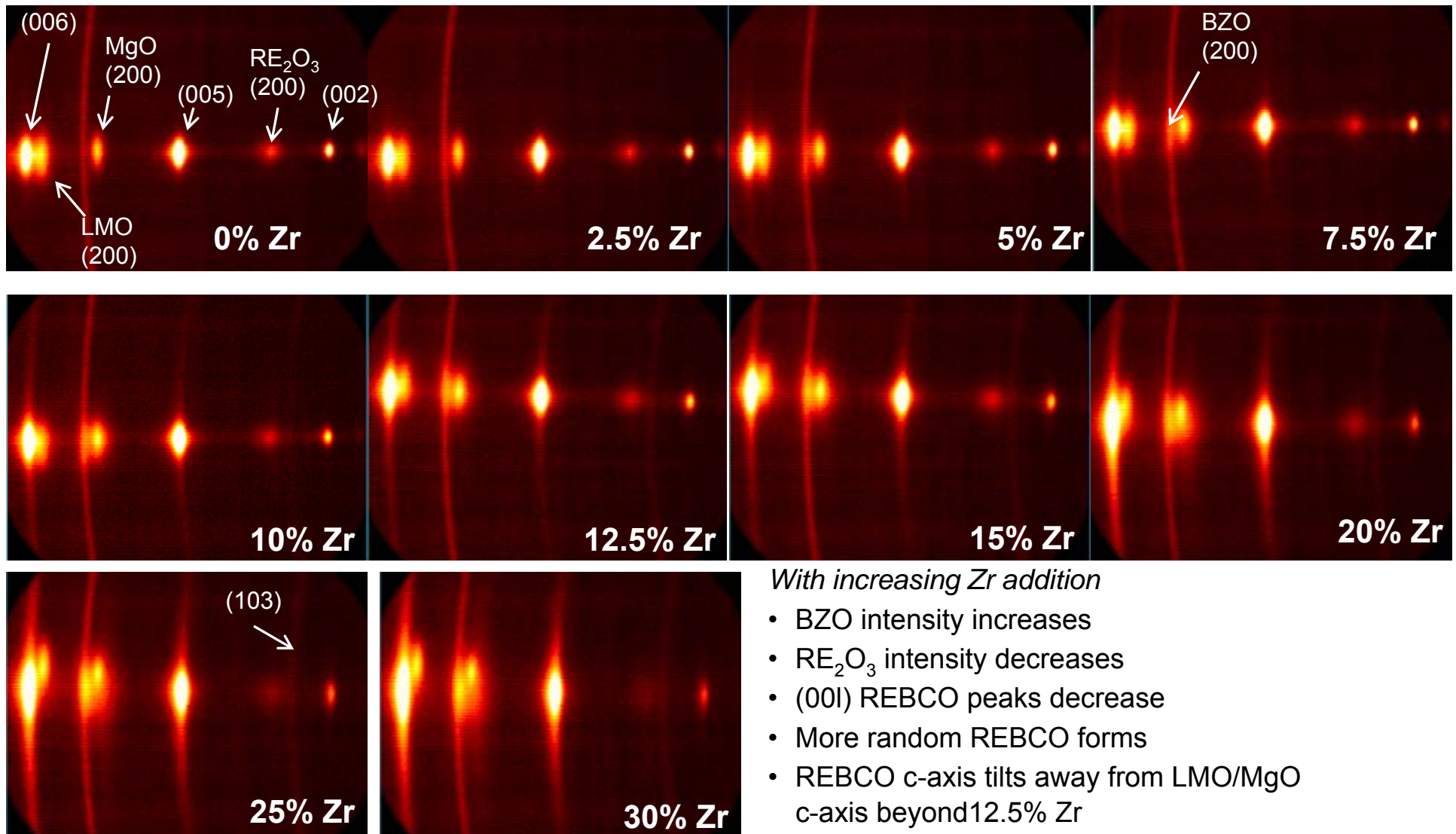

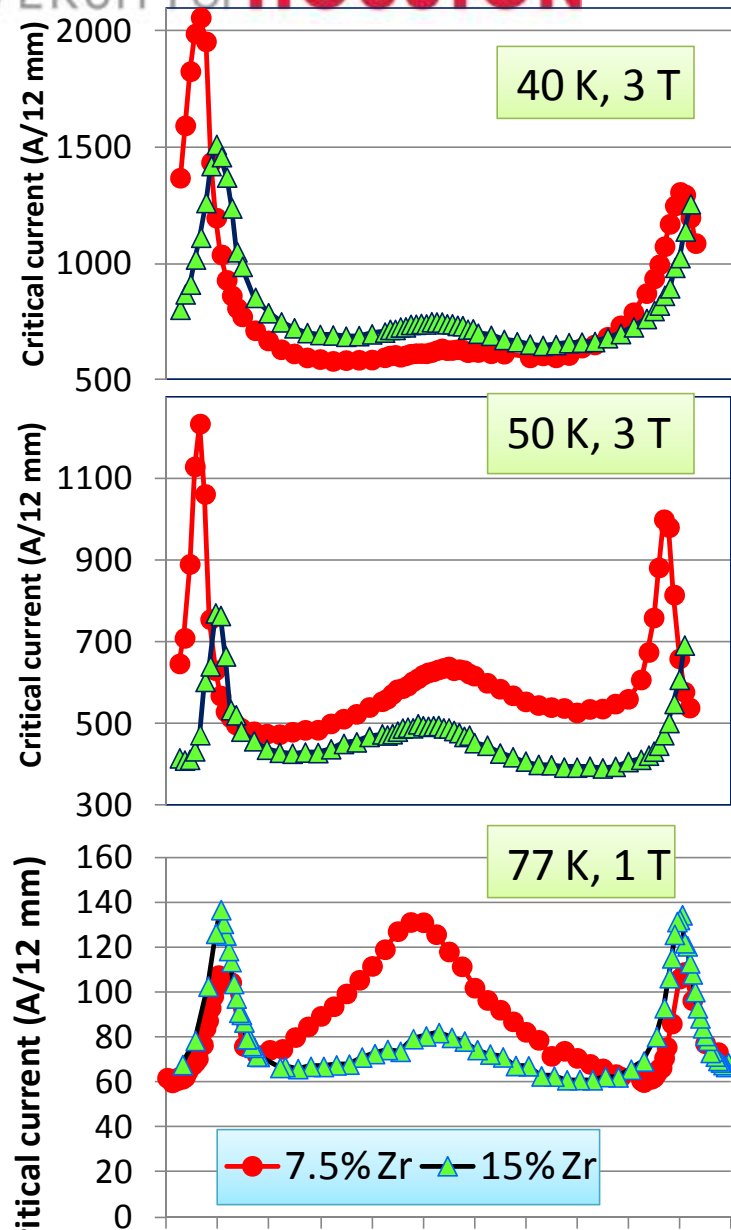

Remarkable changes in Zr-doping effects on performance at lower temperatures

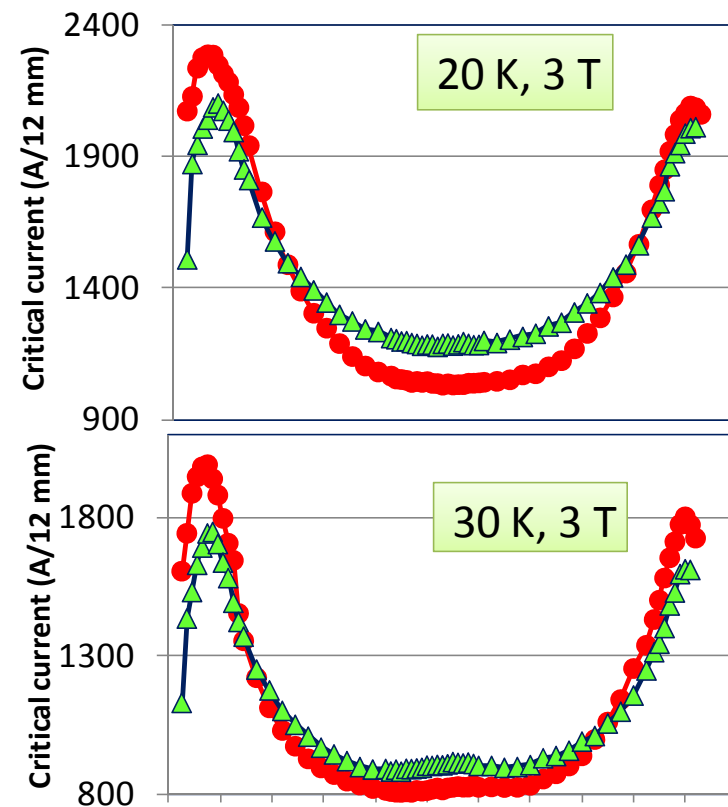

At temperatures of 40 K and below, 15% Zr added film shows higher absolute I_c than 7.5% Zr-added film in spite of lower 77 K, self-field I_c

Remarkable changes in Zr-doping effects on performance at lower temperatures

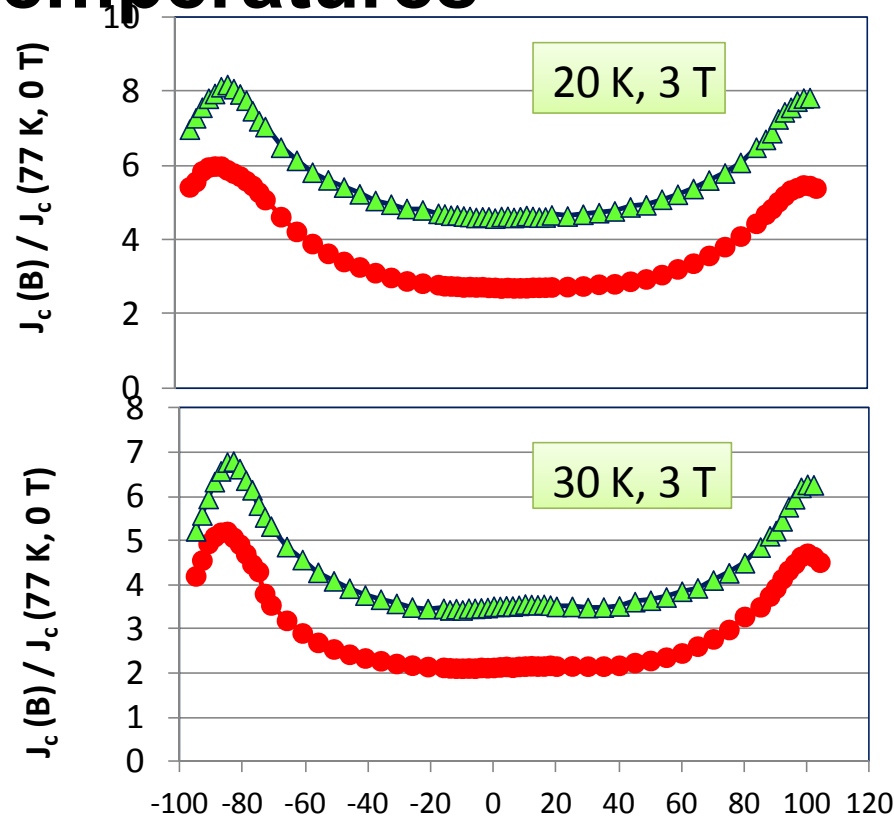
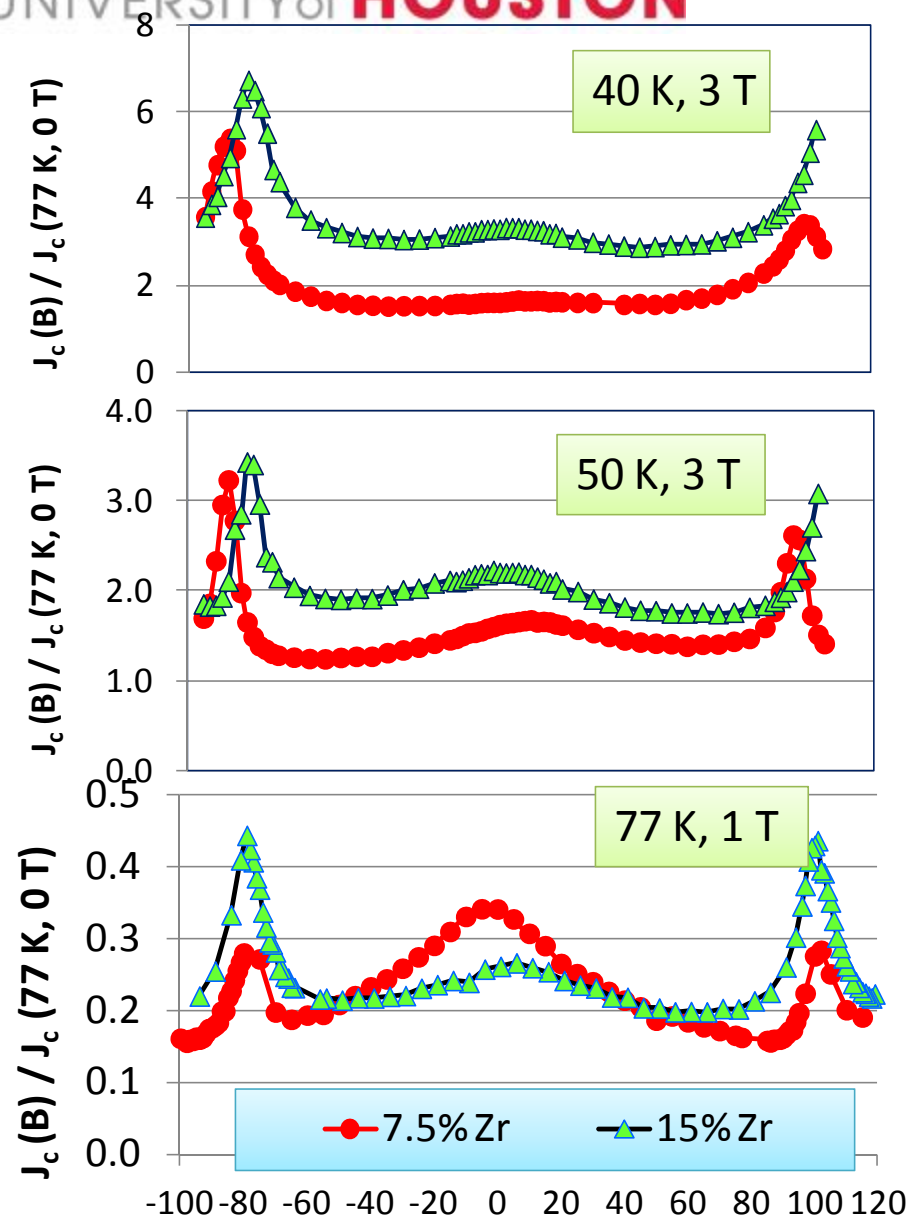

Improved pinning along both a-b plane and c-axis and all angles in high Zr content films at low temperatures

Improved pinning forces in 15% Zr-doped films at temperatures 40 K and below

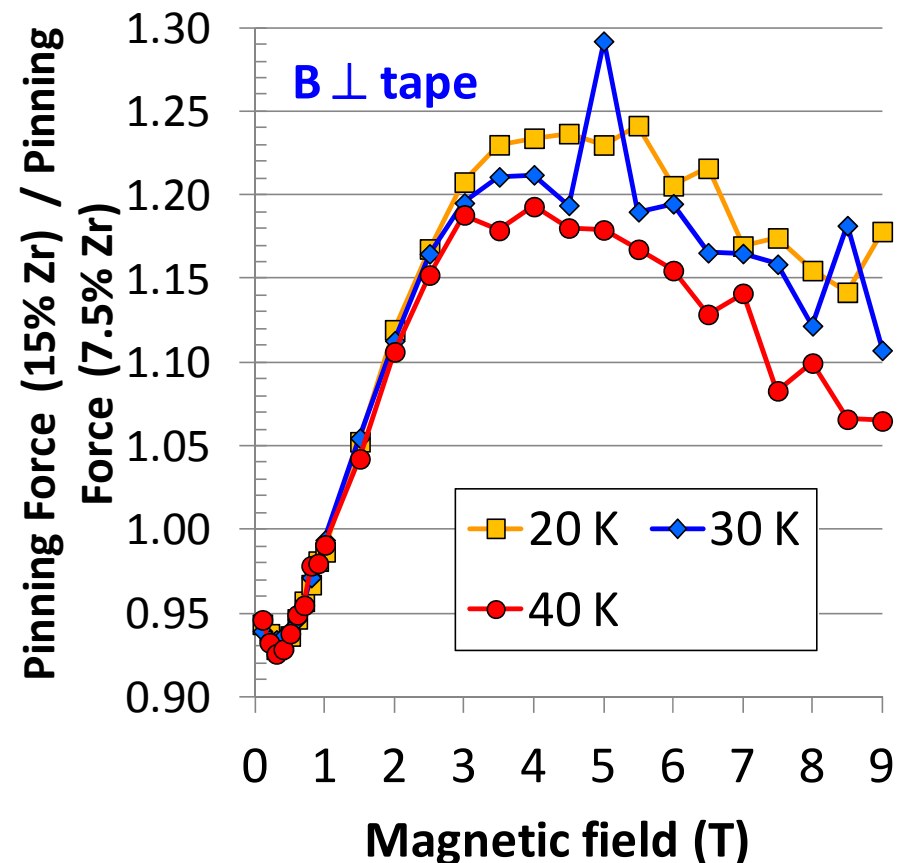
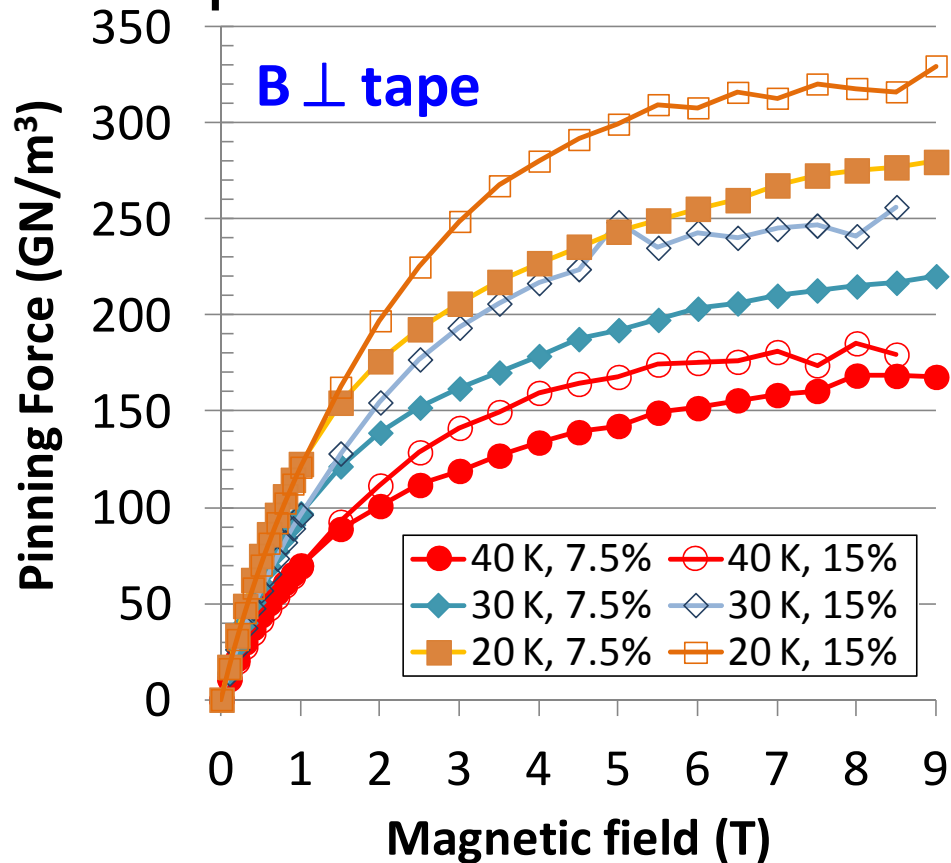

- Pinning force improvement in 15% Zr-added film is enhanced with decreasing temperature
- 15% Zr-added film exhibits higher pinning force at all fields above 1 T
- Maximum pinning force improvement is between 3 and 5 T

Ongoing effort on improving pinning of 2G HTS wires at 40 K and below

- ARPA-E sponsored REACT (Rare-Earth Alternatives in Critical Technologies) program on HTS Wind Generators (2012 – 2014)

Category	Value (Units)
SCALABLE TO POWER	>6 MW
TORQUE	>5MNm
RARE-EARTH PERMANENT MAGNET CONTENT	Zero (0 kg/MW)
COST (LCOE OF WIND GENERATOR DRIVETRAIN)	<\$0.022/kWh
EFFICIENCY (AT RATED RPM)	>95%
ROTOR HUB SPEED	UP TO 12.3 RPM