



superior performance.
powerful technology.

Development of Low AC Loss Multifilamentary 2G Wire at SuperPower

M. Marchevsky, E. Zhang, Y-Y. Xie and V. Selvamanickam

*International Workshop on Coated Conductors for Applications
Houston, TX - USA
December 4-6, 2008*

Work is supported by Air Force Research Lab., Dayton OH

Outline

- Sources of ac losses in 2G wire
- Magnetization loss of the regular SP wire
- NEW striated 2G wires from SuperPower
- Losses in a striated 2G wire: coupling issues
- Coils made with the striated wire: transport ac loss
- Future plans

Magnetization AC losses in 2G superconductor wire

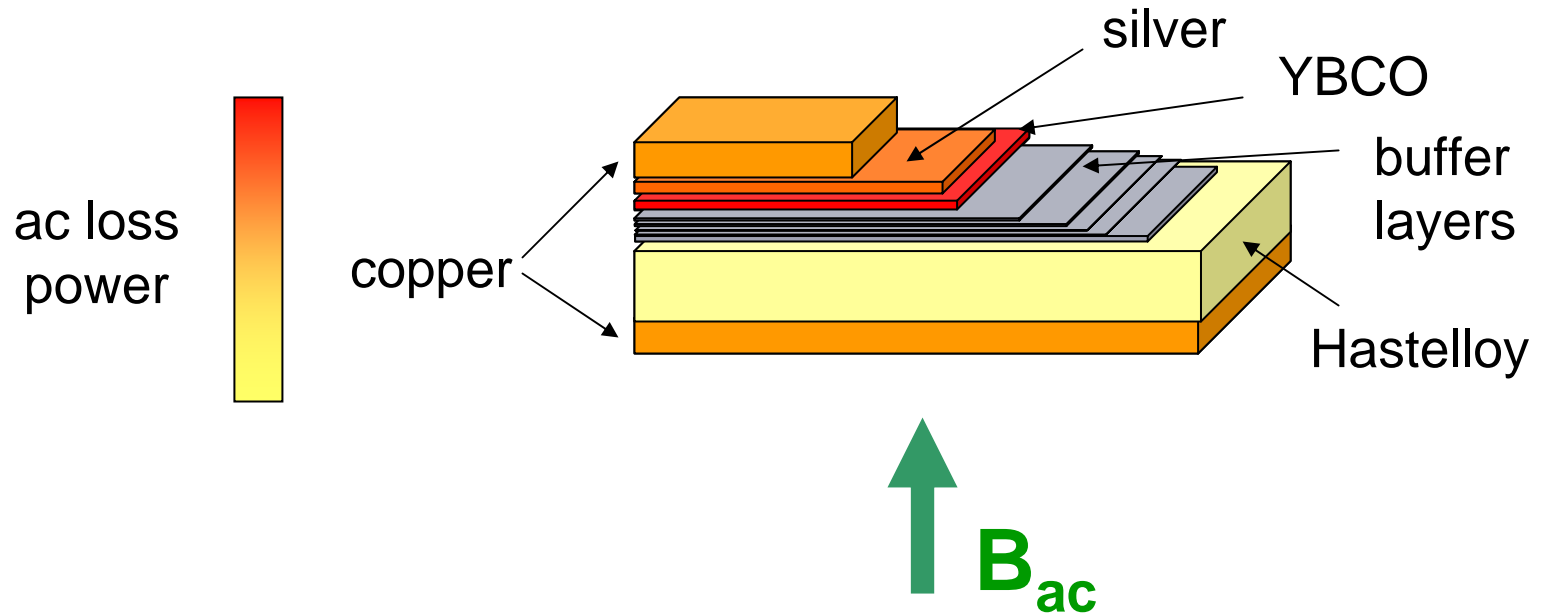

- Hysteretic losses
YBCO layer, losses are largest in perpendicular magnetic field
- Eddy current losses
Cu, Ag and Hastelloy layers

Hysteretic losses: single strip

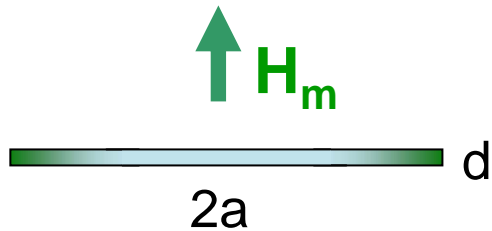

Dividing strip in N parts can reduce hysteretic losses by the factor $\sim N$

$$P = 4 f \mu_0 a^2 J_c H_m g\left(\frac{H_0}{H_c}\right)$$

$$J_c = j_c d = \frac{I_c}{2a}$$

$$H_c = J_c / \pi$$

and

$$g(x) = \frac{2}{x} \ln \cosh x - \tanh x$$

Brandt, et al. 1993

Striation was proposed as a practical way to reduce ac losses of coated conductors

W.J. Carr and C.E. Oberley, 1999

G.A. Levin and P.N. Barnes, 2004

But... coupling losses worsen ac loss reduction in striated wires!

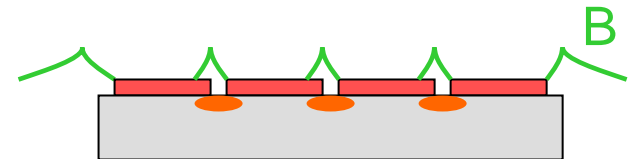

Coupling losses are due to:

- Substrate conductivity (barrier resistance)

- Magnetic coupling

Experimental: ac loss measurement setup

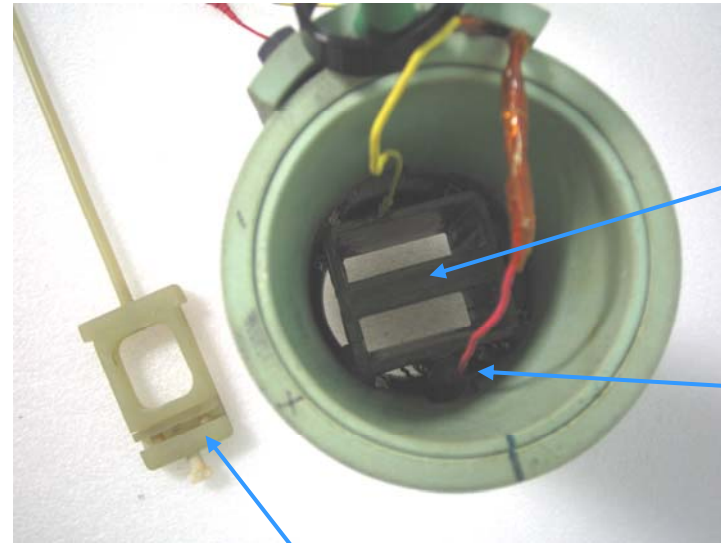
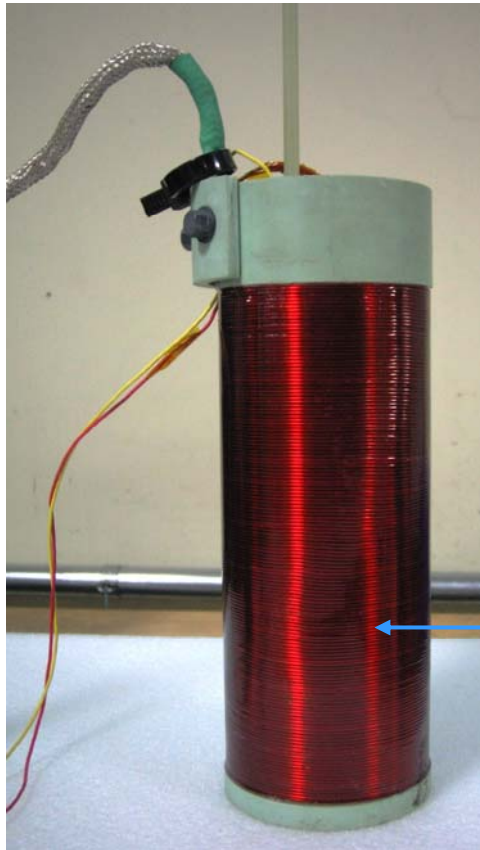

solenoid

sample holder

compensated coil

reference coil

AC field: up to 40 mT r.m.s.
Frequency: up to 400 Hz

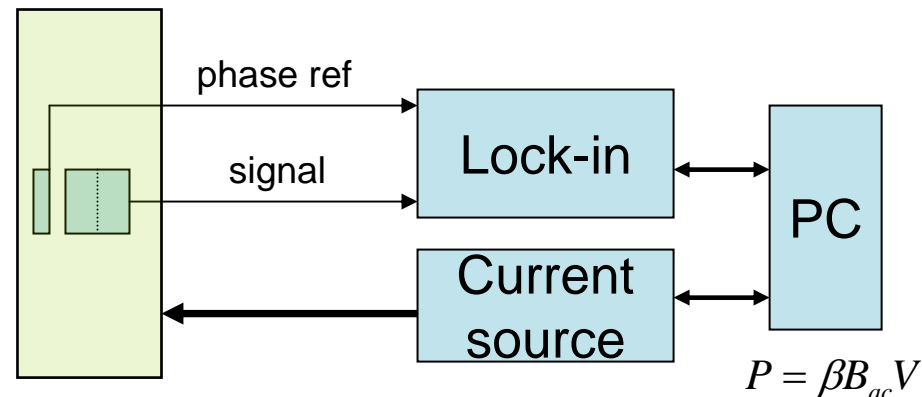

Regular SuperPower® tape wires

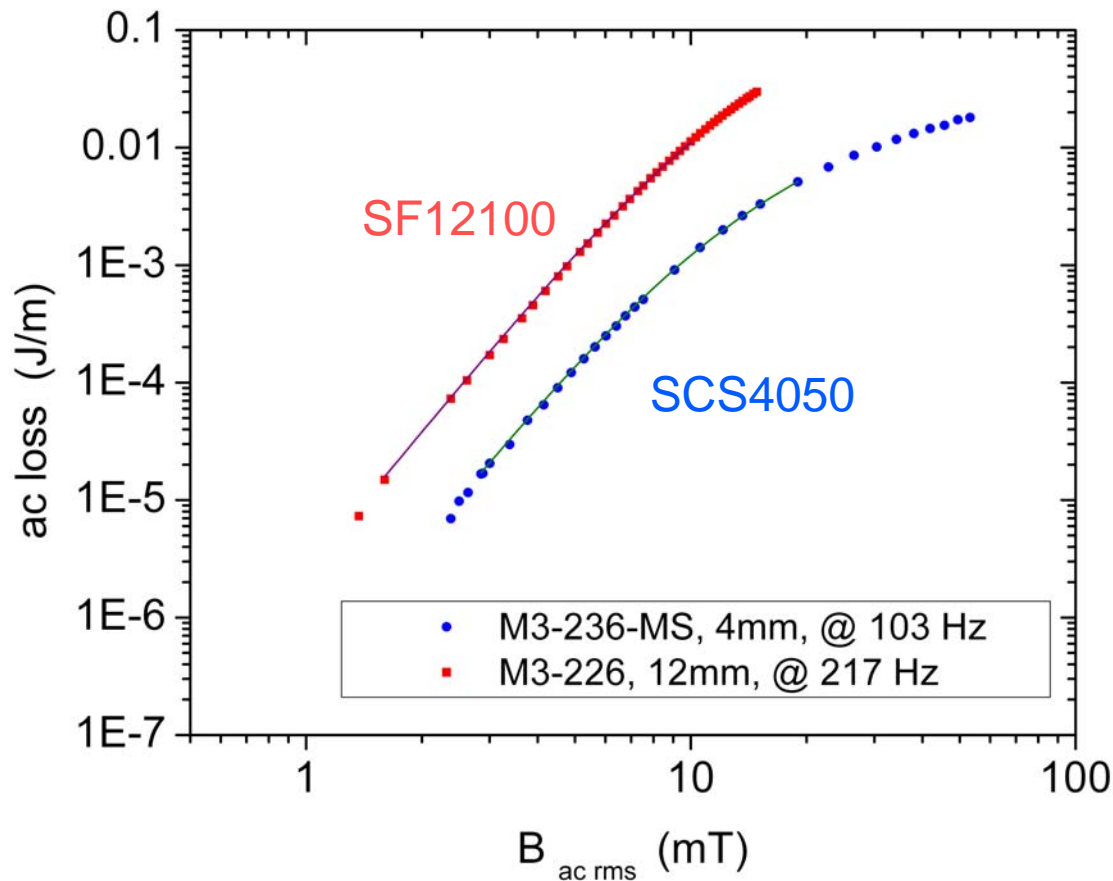

12 mm wide wire SF12100

I_c (actual) = 270 A

I_c (fit) = 290 A

4 mm wide wire SCS4050

I_c (actual) = 80 A

I_c (fit) = 94 A

- A good agreement is seen between the experimental data and the Brandt's model of ac losses => hysteretic loss is dominant

Photolithographic patterning

Tape is patterned using a proprietary dry photolithography process
It involves:

- lamination of the tape with photoresist film
- attachment of flexible photomask directly on top of the photoresist layer
- exposure with UV light source
- photomask removal
- a one-step dry etching process

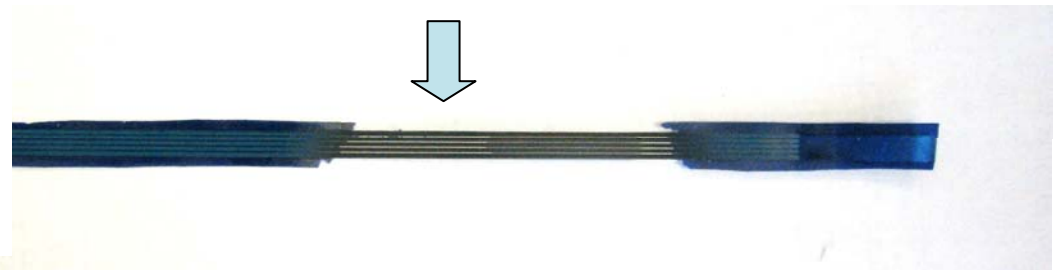
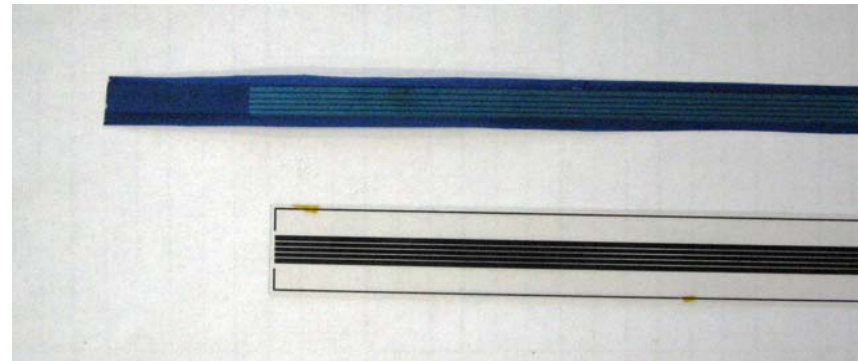
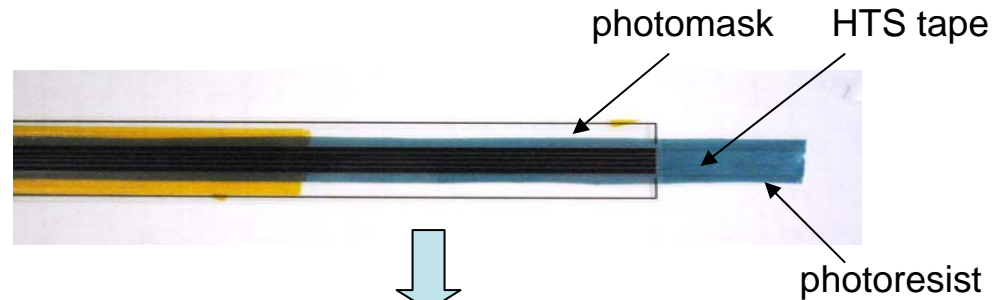

Striated 2G wire fabrication

Problem: (super)conducting residue particles in the trenches

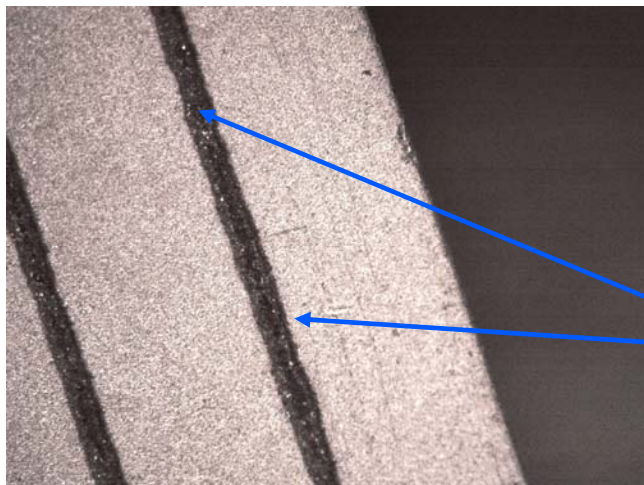
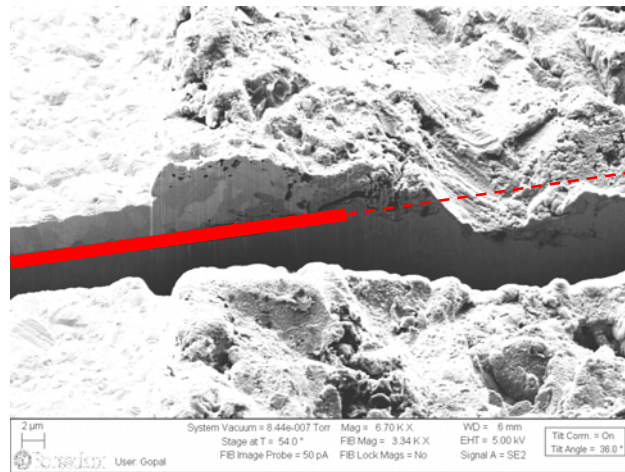
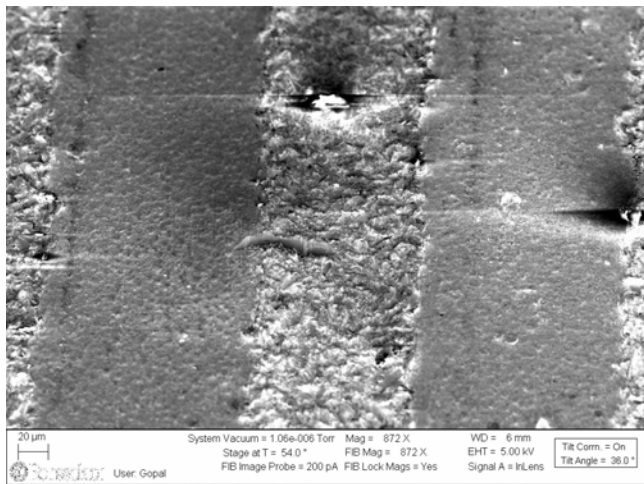

Conducting residue particles (Ag, YBCO) may block the trenches and increase losses due to reduction of barrier resistance and superconducting bridges

Silver particles

**FIB and SEM images by P. Ganesan, Rensselaer Polytechnic Institute, Troy NY*

Frequency-dependent loss contribution

Under-etched sample, with YBCO interconnects and silver remaining in the trenches

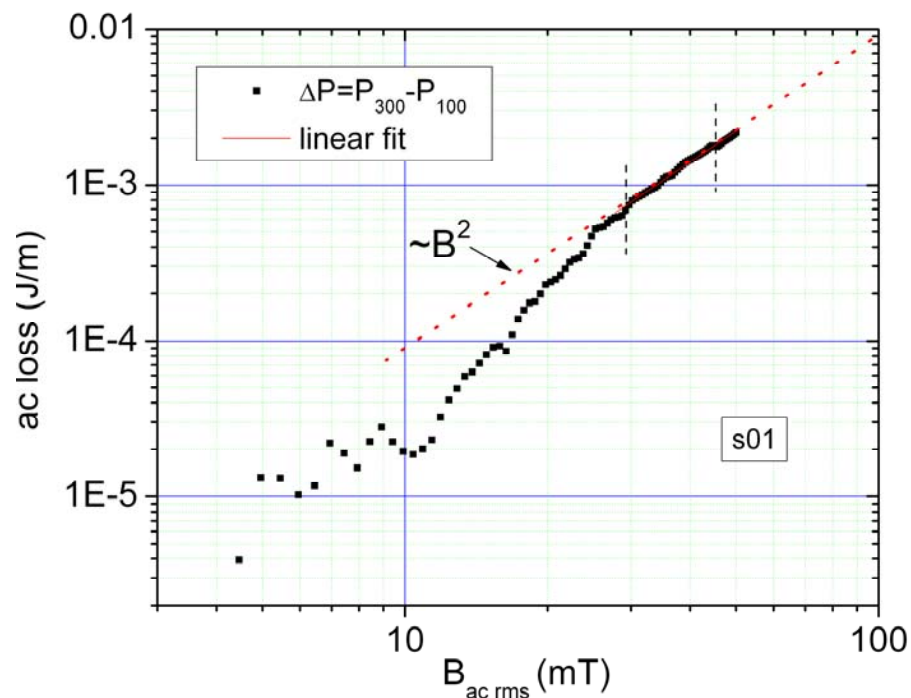
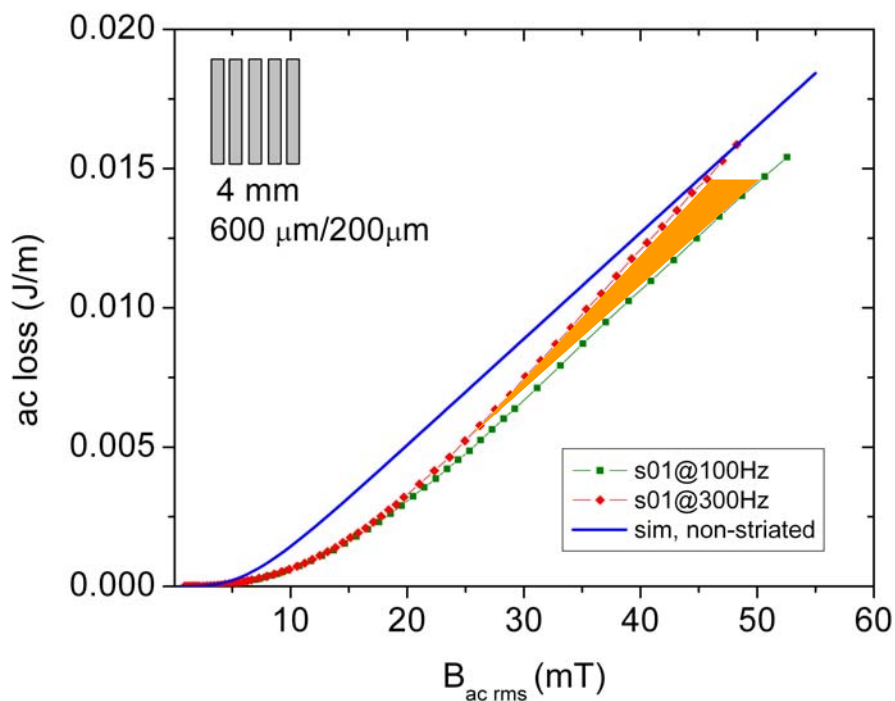

- AC loss reduction is small (20-30%) and losses are frequency-dependent

Optimization of the patterning technique

AC loss is affected by the variation of the etching procedure. Etching optimization and elimination of bridges helps to reduce losses towards the theoretical values

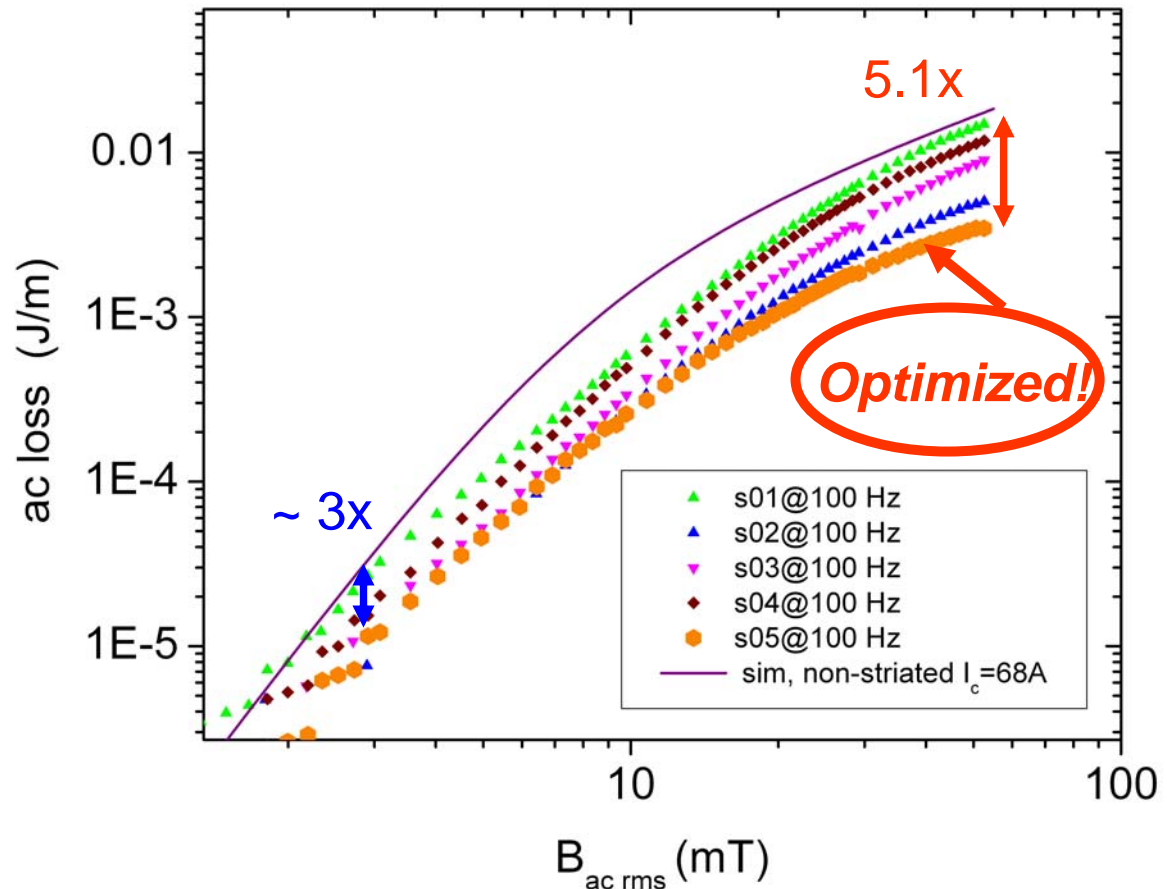
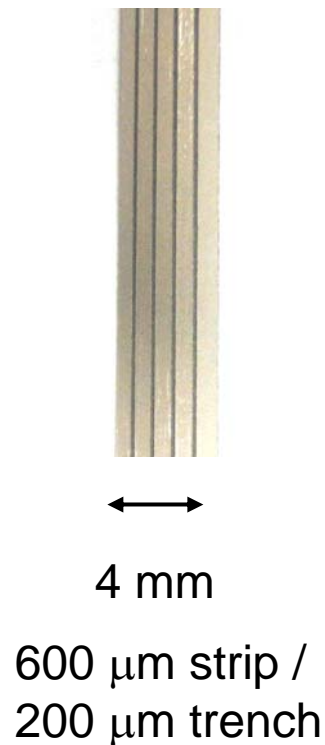

Role of the magnetic coupling

Finite x-array

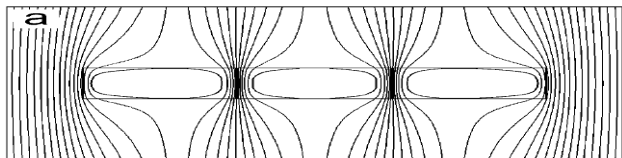

(Adopted from Pardo et al, Phys. Rev. B 67, 104517 (2003))

Field compression between the strips governs the ac loss properties of the array

Infinite x-array

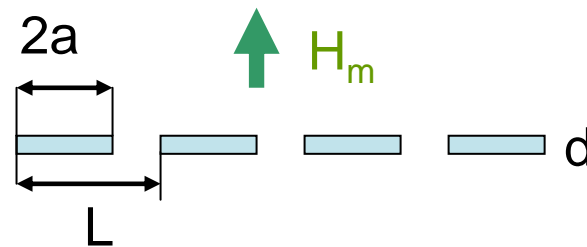

$$P(H_m) = -\frac{2\mu_0 L^2}{\pi a d} \int_0^{H_m} dH_a (H_m - 2H_a) \times \ln \left[1 - \frac{\sin^2(2\pi a / L)}{\cosh^2(H_a / H_0)} \right]$$

Y. Mawatari, Phys. Rev B 54, 13215 (1996)

- *Losses increase due to magnetic coupling, effect is largest at low fields*

Three tape array: experiment on magnetic coupling

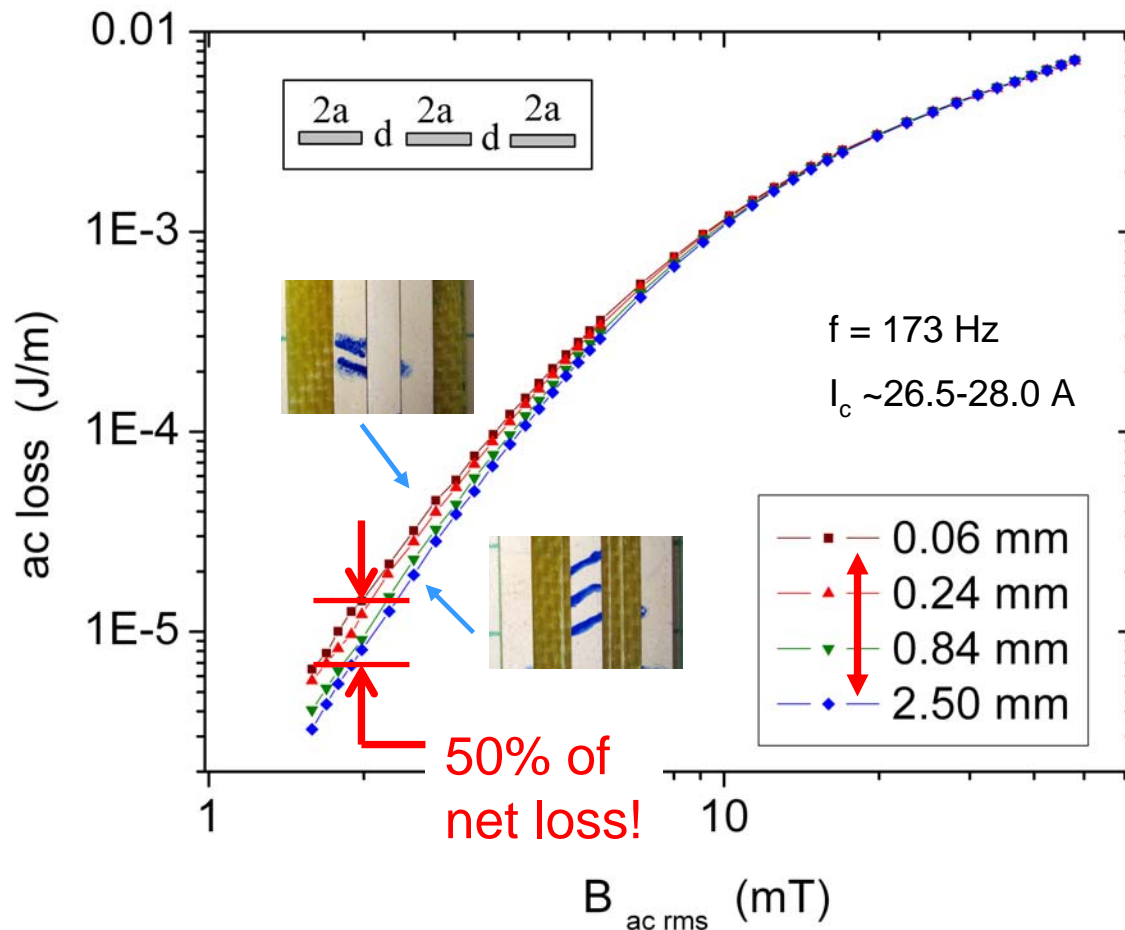

- AC losses increase when separation between tapes is reduced
- Effect is largest below the full penetration field

12 mm-wide striated 2G wire

840 μm strip / 400 μm trench pattern

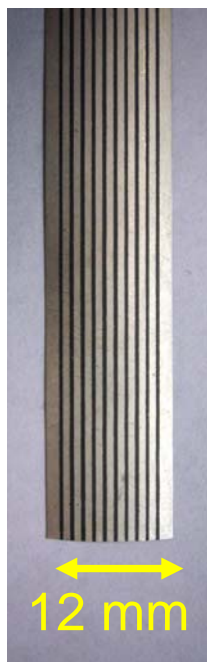

$I_c = 227 \text{ A} / I_{c1} = 152 \text{ A}$

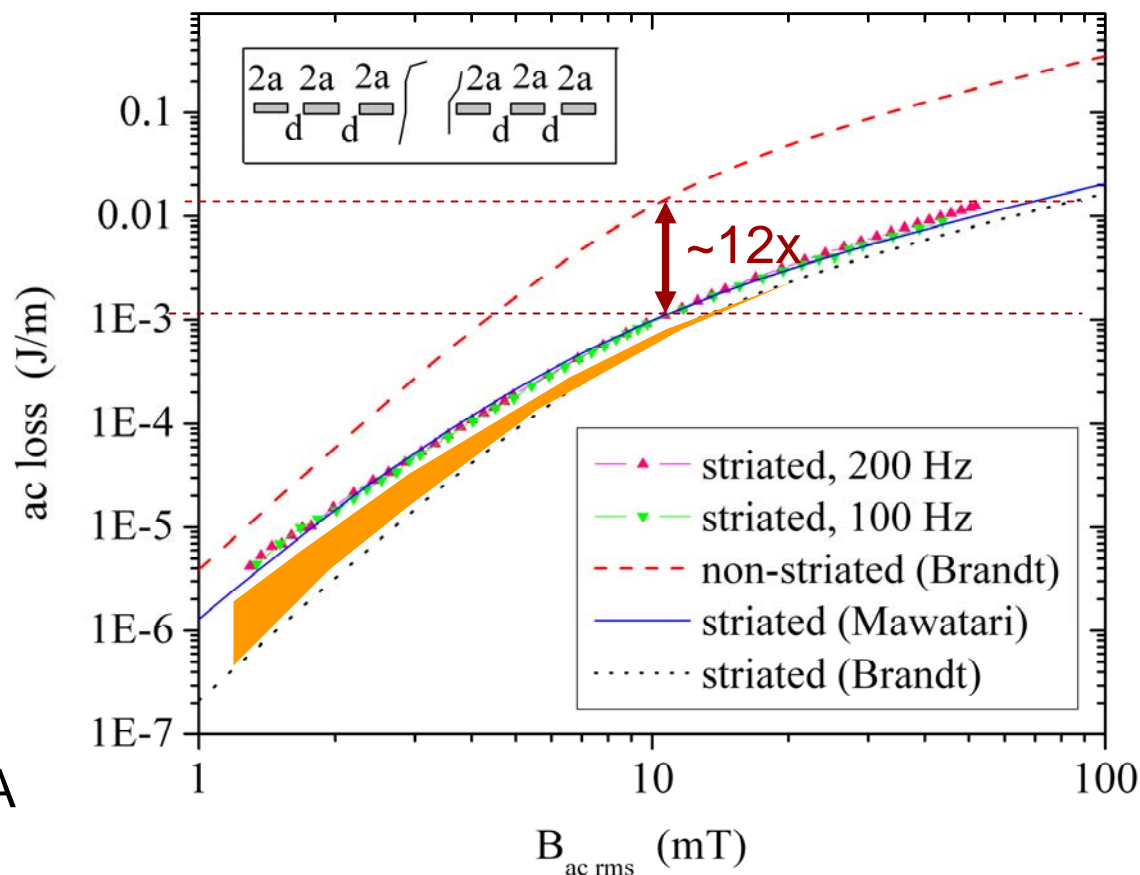

- AC losses can be simulated well with the **Mawatari model**
- No frequency dependence => losses are mainly due to magnetic coupling

Long lengths of striated 2G wire from SuperPower

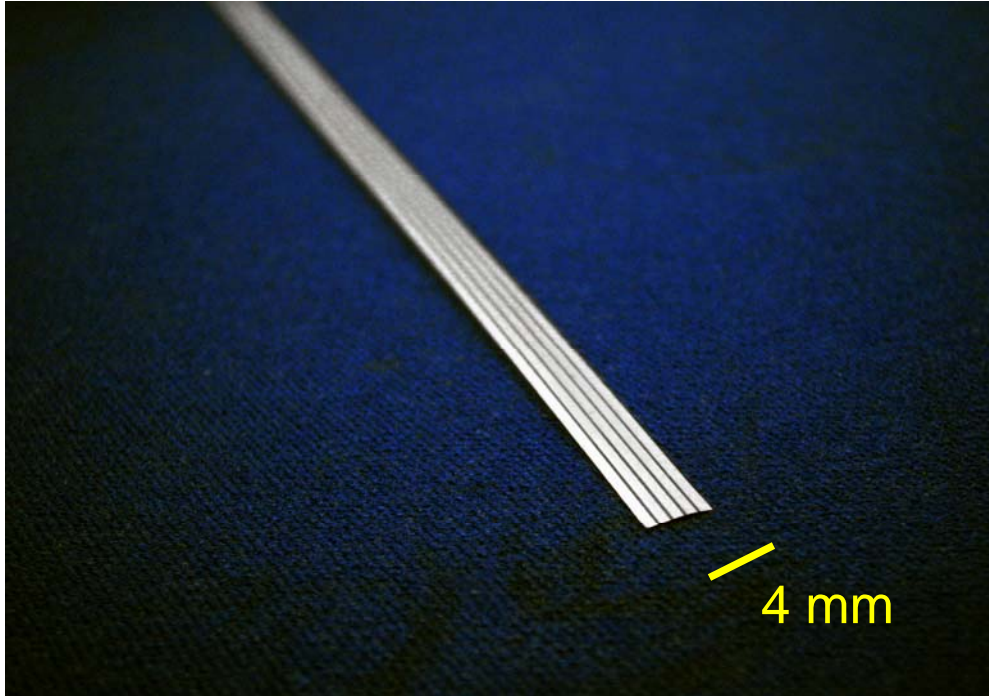

- 600 μm stripe / 200 μm trench (5 stripes)
- $I_c \sim 55\text{-}75\text{ A}$
- $\sim 5\text{x}$ ac loss reduction
- length of 15 m and up



14.5 m of striated wire on a mandrel

Pancake coils made of striated 2G wire



Striated wire coil

Two identically-sized coils were made: one of striated wire and another one of the regular wire
Coil dimensions are:

Bore diameter (mm)	38
Winding ID (mm)	45
Coil OD (mm)	51
Height (mm)	9

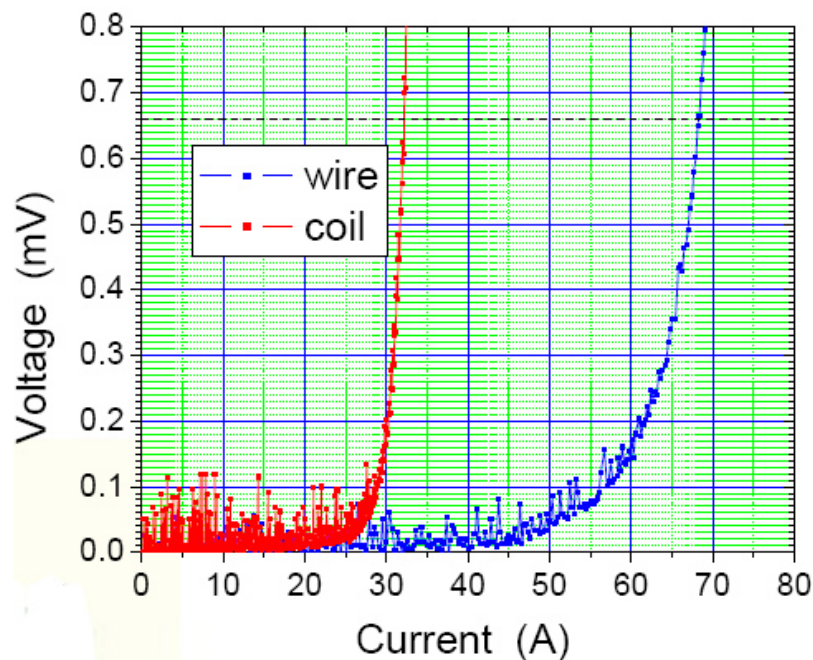

Coil has 43 turns of wire

$I_{c \text{ wire}} = 69 \text{ A}$; $I_{c \text{ coil}} = 32 \text{ A}$

Results of transport ac loss measurements*

*by D. Nguyen and S. Ashworth, Los Alamos National Lab.

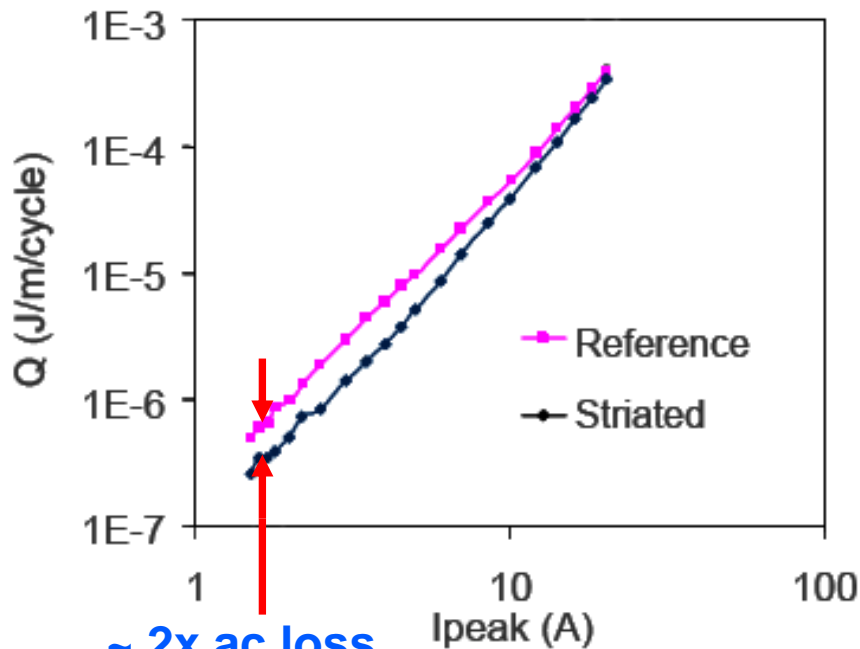

~ 2x ac loss reduction

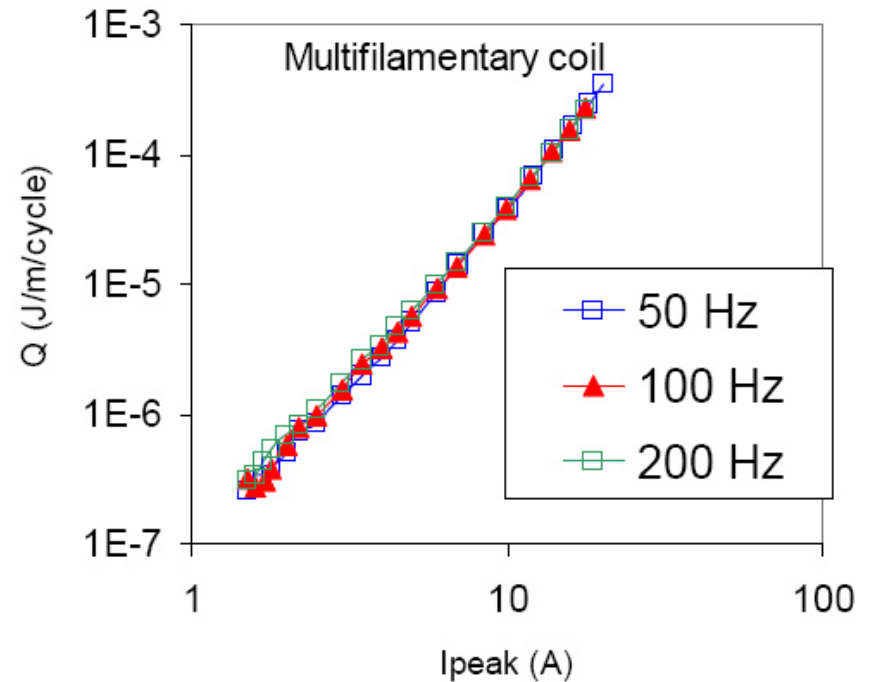

At high current, losses are frequency-independent

Future research and development plans

- Increasing the number of filaments while retaining I_c
- Development of a robust long-length striated wire manufacturing process
- Development of the copper-stabilized striated conductor
- Understanding behavior of coils and stacks of striated conductors in non-uniform fields, at application relevant conditions
- Understanding quench and thermal effects in striated wires and coils